

SONTHEIMER

SINCE 1946



PRODUCTS



ROTARY CAM SWITCHES DATA

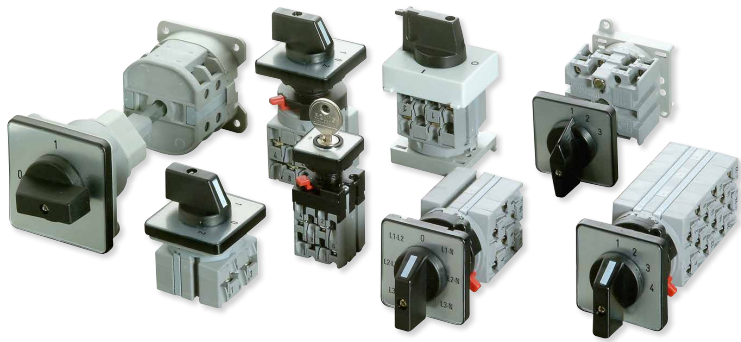

Other configurations and sizes on request

	I _{th} A	AC23 kW (3x400V)	AC3 kW	U V	connection cross mm ²
D00	10	3,0	2,2	500	1,5
D0	25	7,5	5,5	690	4
D1-16	25	9,0	7,5	690	6
D1-20	32	10,5	9,0	690	6
D1-32	45	15,0	11,0	690	6
D1-40	80	22,0	19,0	690	2x16
D1-55	100	37,0	30,0	690	35
D2-63	100	26,5	22,0	690	70
D2-100	125	32,5	27,0	690	70
D2-160	160	40,0	37,0	690	70
D2-126	200	45,5	40,0	690	70
D3-250	315	76,0	64,0	690	185

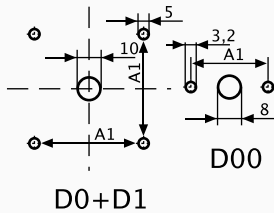
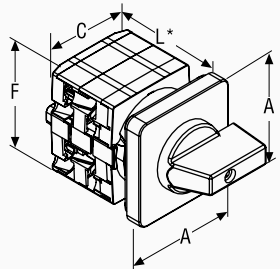

E

TYPE	A	A1	C	F	L1	L2	L3	L4	L5	L6	L7	L8
D00-4	30	20	28	30	29	37	45	53	61	69	77	85
D00-6	30	20	30	28	33	45	57	69	81	93	105	117
D0-7	48	36	40	39	34	46	58	70	82	94	106	118
D0-8	48	36	40	39	34	46	58	70	82	94	106	118
D0-13	48	36	43	43	32	41	51	60	70	79	89	98
D1-16	66	48	54	56	40	53	66	79	92	105	118	131
D1-20	66	48	54	56	40	53	66	79	92	105	118	131
D1-32	66	48	54	56	40	53	66	79	92	105	118	131
D1-40	66	48	68	64	50	71	92	113	134	155	176	197

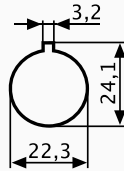
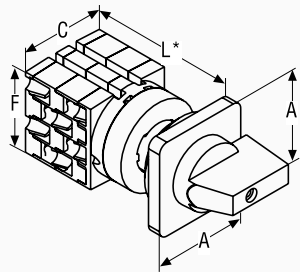

ZM

TYPE	A	C	F	L1	L2	L3	L4	L5	L6	L7	L8
D00-4	30	28	30	43	51	59	67	75	83	91	99
D00-6	30	30	28	46	58	70	82	94	106	118	130
D0-7	48	40	43	58	70	82	94	106	118	130	142
D0-8	48	40	39	58	70	82	94	106	118	130	142
D0-13	48	43	43	56	65	75	84	94	103	113	122
D1-16	66	54	56	60	73	86	99	112	125	138	151
D1-20	66	54	56	60	73	86	99	112	125	138	151
D1-32	66	54	56	60	73	86	99	112	125	138	151
D1-40	66	68	64	70	91	112	133	154	175	196	217

IP65

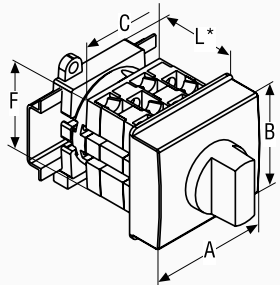

T

TYPE	A	B	C	F	L1	L2	L3				
D00-6	35	45	28	30	45	45	45				
D0-8	52,5	45	40	39	45	45	45				
D1-16	52,5	45	54	56	45	45	56				
D1-20	52,5	45	54	56	45	45	56				
D1-32	52,5	45	54	56	45	45	56				

Connection diagram	Thermal rated current I_{th} (in A)	Rated perf. at 3x400V (in kW)	4-Hole mounting			Central mounting			DIN-Railmounting		
			Type	Type	Type	Type	Type				
90° Off/On switch F 908 1-pole	10	2,2	A1/ 4	E	A1/ 4	ZM					
	10	2,2	A1/ 6	E	A1/ 6	ZM	A1/ 6	T			
	25	5,5	A1/ 7	E	A1/ 7	ZM					
	25	5,5	A1/ 8	E	A1/ 8	ZM	A1/ 8	T			
	25	7,5	A1/ 16	E	A1/ 16	ZM	A1/ 16	T			
	32	9,0	A1/ 20	E	A1/ 20	ZM	A1/ 20	T			
45	11,0	A1/ 32	E	A1/ 32	ZM	A1/ 32	T				
90° Off/On switch F 908 3-pole	10	2,2	A3/ 4	E	A3/ 4	ZM					
	10	2,2	A3/ 6	E	A3/ 6	ZM	A3/ 6	T			
	25	5,5	A3/ 7	E	A3/ 7	ZM					
	25	5,5	A3/ 8	E	A3/ 8	ZM	A3/ 8	T			
	25	7,5	A3/ 16	E	A3/ 16	ZM	A3/ 16	T			
	32	9,0	A3/ 20	E	A3/ 20	ZM	A3/ 20	T			
45	11,0	A3/ 32	E	A3/ 32	ZM	A3/ 32	T				
90° Off/On switch F 908 4-pole	10	2,2	A4/ 4	E	A4/ 4	ZM					
	10	2,2	A4/ 6	E	A4/ 6	ZM	A4/ 6	T			
	25	5,5	A4/ 7	E	A4/ 7	ZM					
	25	5,5	A4/ 8	E	A4/ 8	ZM	A4/ 8	T			
	25	7,5	A4/ 16	E	A4/ 16	ZM	A4/ 16	T			
	32	9,0	A4/ 20	E	A4/ 20	ZM	A4/ 20	T			
45	11,0	A4/ 32	E	A4/ 32	ZM	A4/ 32	T				
60° Change-over switch F 604 1-pole	10	2,2	U1/ 4	E	U1/ 4	ZM					
	10	2,2	U1/ 6	E	U1/ 6	ZM	U1/ 6	T			
	25	5,5	U1/ 7	E	U1/ 7	ZM					
	25	5,5	U1/ 8	E	U1/ 8	ZM	U1/ 8	T			
	25	7,5	U1/ 16	E	U1/ 16	ZM	U1/ 16	T			
	32	9,0	U1/ 20	E	U1/ 20	ZM	U1/ 20	T			
45	11,0	U1/ 32	E	U1/ 32	ZM	U1/ 32	T				
60° Change-over switch F 604 2-pole	10	2,2	U2/ 4	E	U2/ 4	ZM					
	10	2,2	U2/ 6	E	U2/ 6	ZM	U2/ 6	T			
	25	5,5	U2/ 7	E	U2/ 7	ZM					
	25	5,5	U2/ 8	E	U2/ 8	ZM	U2/ 8	T			
	25	7,5	U2/ 16	E	U2/ 16	ZM	U2/ 16	T			
	32	9,0	U2/ 20	E	U2/ 20	ZM	U2/ 20	T			
45	11,0	U2/ 32	E	U2/ 32	ZM	U2/ 32	T				
Change-over switch with double-sided return F 312 1-pole	10	2,2	URR1/ 4	E	URR1/ 4	ZM					
	10	2,2	URR1/ 6	E	URR1/ 6	ZM	URR1/ 6	T			
	25	5,5	URR1/ 7	E	URR1/ 7	ZM					
	25	5,5	URR1/ 8	E	URR1/ 8	ZM	URR1/ 8	T			
	25	7,5	URR1/ 16	E	URR1/ 16	ZM	URR1/ 16	T			
	32	9,0	URR1/ 20	E	URR1/ 20	ZM	URR1/ 20	T			
45	11,0	URR1/ 32	E	URR1/ 32	ZM	URR1/ 32	T				
60° Change-over switch F 614 1-pole	10	2,2	WS1/ 4	E	WS1/ 4	ZM					
	10	2,2	WS1/ 6	E	WS1/ 6	ZM	WS1/ 6	T			
	25	5,5	WS1/ 7	E	WS1/ 7	ZM					
	25	5,5	WS1/ 8	E	WS1/ 8	ZM	WS1/ 8	T			
	25	7,5	WS1/ 16	E	WS1/ 16	ZM	WS1/ 16	T			
	32	9,0	WS1/ 20	E	WS1/ 20	ZM	WS1/ 20	T			
45	11,0	WS1/ 32	E	WS1/ 32	ZM	WS1/ 32	T				
Step switch, 3 positions F 302 1-pole	10	2,2	ST31/ 4	E	ST31/ 4	ZM					
	10	2,2	ST31/ 6	E	ST31/ 6	ZM	ST31/ 6	T			
	25	5,5	ST31/ 7	E	ST31/ 7	ZM					
	25	5,5	ST31/ 8	E	ST31/ 8	ZM	ST31/ 8	T			
	25	7,5	ST31/ 16	E	ST31/ 16	ZM	ST31/ 16	T			
	32	9,0	ST31/ 20	E	ST31/ 20	ZM	ST31/ 20	T			
45	11,0	ST31/ 32	E	ST31/ 32	ZM	ST31/ 32	T				
Step switch, 3 positions + off position F 315 1-pole	10	2,2	ST031/ 4	E	ST031/ 4	ZM					
	10	2,2	ST031/ 6	E	ST031/ 6	ZM	ST031/ 6	T			
	25	5,5	ST031/ 7	E	ST031/ 7	ZM					
	25	5,5	ST031/ 8	E	ST031/ 8	ZM	ST031/ 8	T			
	25	7,5	ST031/ 16	E	ST031/ 16	ZM	ST031/ 16	T			
	32	9,0	ST031/ 20	E	ST031/ 20	ZM	ST031/ 20	T			
45	11,0	ST031/ 32	E	ST031/ 32	ZM	ST031/ 32	T				

ROTARY CAM SWITCHES

Connection diagram

Step switch, 3 positions + Off position

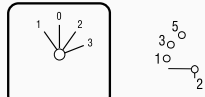

2Ka-A1142a F 375 1-pole

Voltmeter change-over switch

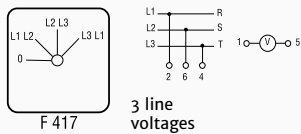

2Ka-A1086 F 417 3 line voltages

Voltmeter change-over switch

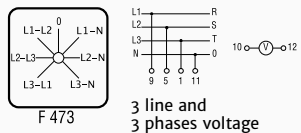

3Ka-A1088 F 473 3 line and 3 phases voltage

Ammeter change-over switch

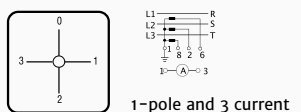

3Ka-A1092 F 904 1-pole and 3 current changer circuits

Star delta switch, 1 direction

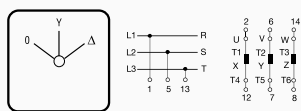

4Ka-A1031 F 607

Pole change switch

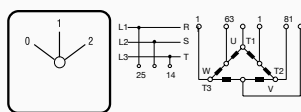

4Ka-A1044 F 603 1-pole

Binary code switch

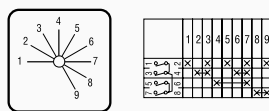

2Ka-A1410 F 308 1-pole

Binary code switch

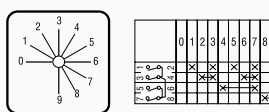

2Ka-A1413 F 321 1-pole

Stop/Start switch

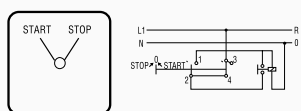

2Ka-A1103 F 330 1-pole

Thermal rated current I_{th} (in A)	Rated perf. at 3x400V (in KW)	4-Hole mounting		Central mounting		DIN-Railmounting	
		Type	Type	Type	Type		
10	2,2	ST031/ 4	E/F375	ST031/ 4	ZM/F375		
10	2,2	ST031/ 6	E/F375	ST031/ 6	ZM/F375	ST031/ 6	T/F375
25	5,5	ST031/ 7	E/F375	ST031/ 7	ZM/F375		
25	5,5	ST031/ 8	E/F375	ST031/ 8	ZM/F375	ST031/ 8	T/F375
25	7,5	ST031/ 16	E/F375	ST031/ 16	ZM/F375	ST031/ 16	T/F375
32	9,0	ST031/ 20	E/F375	ST031/ 20	ZM/F375	ST031/ 20	T/F375
45	11,0	ST031/ 32	E/F375	ST031/ 32	ZM/F375	ST031/ 32	T/F375
10	2,2	V3/ 4	E	V3/ 4	ZM		
10	2,2	V3/ 6	E	V3/ 6	ZM	V3/ 6	T
25	5,5	V3/ 7	E	V3/ 7	ZM		
25	5,5	V3/ 8	E	V3/ 8	ZM	V3/ 8	T
25	7,5	V3/ 16	E	V3/ 16	ZM		
10	2,2	V30/ 4	E	V30/ 4	ZM		
10	2,2	V30/ 6	E	V30/ 6	ZM	V30/ 6	T
25	5,5	V30/ 7	E	V30/ 7	ZM		
25	5,5	V30/ 8	E	V30/ 8	ZM	V30/ 8	T
25	7,5	V30/ 16	E	V30/ 16	ZM		
10	2,2	AU31/ 4	E	AU31/ 4	ZM		
10	2,2	AU31/ 6	E	AU31/ 6	ZM	AU31/ 6	T
25	5,5	AU31/ 7	E	AU31/ 7	ZM		
25	5,5	AU31/ 8	E	AU31/ 8	ZM	AU31/ 8	T
25	7,5	AU31/ 16	E	AU31/ 16	ZM		
10	2,2	SD/ 4	E	SD/ 4	ZM		
10	2,2	SD/ 6	E	SD/ 6	ZM		
25	5,5	SD/ 7	E	SD/ 7	ZM		
25	5,5	SD/ 8	E	SD/ 8	ZM		
25	7,5	SD/ 16	E	SD/ 16	ZM		
32	9,0	SD/ 20	E	SD/ 20	ZM		
45	11,0	SD/ 32	E	SD/ 32	ZM		
10	2,2	P12/ 4	E	P12/ 4	ZM		
10	2,2	P12/ 6	E	P12/ 6	ZM		
25	5,5	P12/ 7	E	P12/ 7	ZM		
25	5,5	P12/ 8	E	P12/ 8	ZM		
25	7,5	P12/ 16	E	P12/ 16	ZM		
32	9,0	P12/ 20	E	P12/ 20	ZM		
45	11,0	P12/ 32	E	P12/ 32	ZM		
10	2,2	BC9/ 4	E	BC9/ 4	ZM		
10	2,2	BC9/ 6	E	BC9/ 6	ZM	BC9/ 6	T
25	5,5	BC9/ 7	E	BC9/ 7	ZM		
25	5,5	BC9/ 8	E	BC9/ 8	ZM	BC9/ 8	T
10	2,2	BC09/ 4	E	BC09/ 4	ZM		
10	2,2	BC09/ 6	E	BC09/ 6	ZM	BC09/ 6	T
25	5,5	BC09/ 7	E	BC09/ 7	ZM		
25	5,5	BC09/ 8	E	BC09/ 8	ZM	BC09/ 8	T
10	2,2	SEA1/ 4	E	SEA1/ 4	ZM		
10	2,2	SEA1/ 6	E	SEA1/ 6	ZM	SEA1/ 6	T
25	5,5	SEA1/ 7	E	SEA1/ 7	ZM		
25	5,5	SEA1/ 8	E	SEA1/ 8	ZM	SEA1/ 8	T

ON LOAD SWITCHES LT DATA

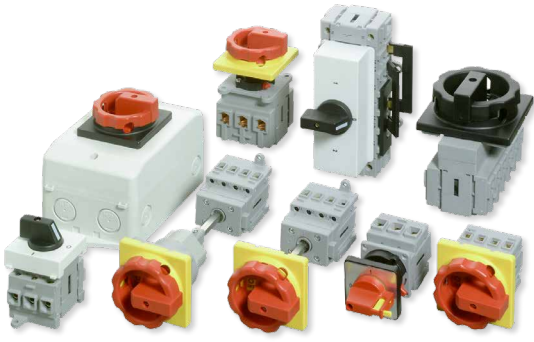

Other configurations and sizes on request

	I_{th} A	AC23 kW (3x400V)	AC3 kW	U V	connection cross mm ²
LT16	16	7,5	5,5	690	6
LT25A	25	9,5	7,5	690	6
LT32	32	11,5	9,5	690	16
LT40	40	20,0	11,0	690	16
LT63	63	22,0	18,5	690	35
LT80	80	30,0	22,0	690	35
LT100	100	37,0	30,0	690	50
LT125	125	45,0	37,0	690	50
LT180	180	90,0	75,0	690	185
LT250	250	132,0	110,0	690	185
H11	10			240	4

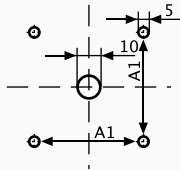
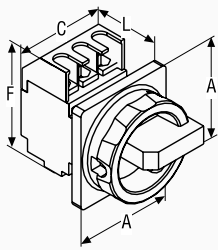

E

TYPE	A	A1	C 3pol	C 4pol	C 6pol	C 8pol	F	L
LT16-LT25A	66	48	48	48	/	/	62	50
LT32-LT40	66	48	45	61	91	122	72	50
ULT25-ULT40	64	48	91	122	/	/	72	64
LT63-LT80	66	48	60	80	121	161	83	59
ULT63-ULT80	64	48	121	161	/	/	83	74
LT100-LT125	66	48	70	93	141	187	96	75
ULT100-ULT125	64	48	141	187	/	/	96	90
LT180-LT250	94	68	112	150	224	300	169	93
ULT180-ULT250	94	68	224	300	/	/	169	110

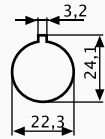
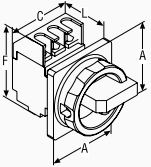

ZM

IP65

TYPE	A	C 3pol	C 4pol	F	L
LT16-LT25A	66	48	48	62	73
LT32-LT40	66	45	61	72	73
LT63-LT80	66	60	80	83	84

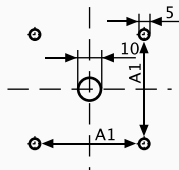
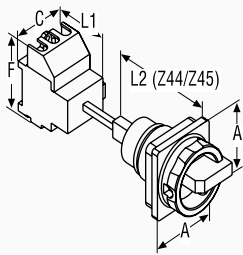

V

TYPE	A	A1	C 3pol	C 4pol	C 6pol	C 8pol	F	L1	L2 Z44/Z45
LT16-LT25A	66	48	48	48	/	/	62	50	80
LT32-LT40	66	48	45	61	91	122	72	50	80
ULT25-ULT40	64	48	91	122	/	/	72	64	80
LT63-LT80	66	48	60	80	121	161	83	59	80
ULT63-ULT80	64	48	121	161	/	/	83	74	80
LT100-LT125	66	48	70	93	141	187	96	75	80
ULT100-ULT125	64	48	141	187	/	/	96	90	80
LT180-LT250	94	68	112	150	224	300	169	93	47
ULT180-ULT250	94	68	224	300	/	/	148	110	47

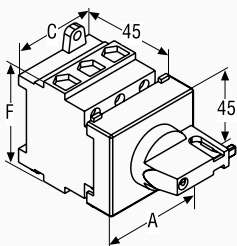

T

TYPE	A 3pol	A 4pol	A 6pol	A 8pol	F	C 3pol	C 4pol	C 6pol	C 8pol
LT16-LT25A	52,5	52,5	52,5	/	50	48	48	/	/
LT32-LT40	52,5	65	98	98	55	45	61	91	122
ULT25-ULT40	98	98	/	/	55	91	122	/	/
LT63-LT80	63	83	125	125	64	60	80	121	161
ULT63-ULT80	125	125	/	/	64	121	161	/	/
LT100-LT125	70	93	140	140	83	70	93	141	187
ULT100-ULT125	140	140	/	/	83	141	187	/	/

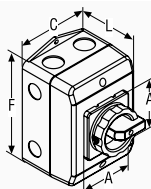

Sheet metal enclosures and EMC-accessories

Enclosures

IP65

TYPE	A	C	F	L	Knockouts
PM-D1/Z33	66	100	140	81	4 x M25, 4 x M20
PM-D2/Z33	66	146	176	104	4 x M32/40, 4 x M20
PM-D3/Z33	90	302	212	137	4 x M50/63, 6 x M20
K4/Z33	90	373	373	230	2 x M40/63, 2 x M32/50, 4 x M25/40

ON LOAD SWITCHES LT

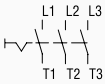
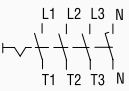
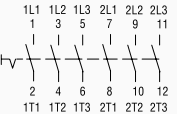
Connection diagram	Thermal rated current I_{th} (in A)	Rated perf. at 3x400V (in kW)	Rated perf. at 3x400V (in kW)	4-Hole mounting	Central mounting	Base mounting	
	I_{th}	AC3	AC23	Type	Type	Type	
	3-pole	16	5,5	7,5	E NLT 16/ 3E/ Z33 HLT 16/ 3E/ Z33	ZM NLT 16/ 3ZM/ Z33 HLT 16/ 3ZM/ Z33	V NLT 16/ 3V/ Z33/ 45 HLT 16/ 3V/ Z33/ 45
		25	7,5	9,5	NLT 25/ 3E/ Z33 HLT 25/ 3E/ Z33	NLT 25/ 3ZM/ Z33 HLT 25/ 3ZM/ Z33	NLT 25/ 3V/ Z33/ 45 HLT 25/ 3V/ Z33/ 45
		32	9,5	11,5	NLT 32/ 3E/ Z33 HLT 32/ 3E/ Z33	NLT 32/ 3ZM/ Z33 HLT 32/ 3ZM/ Z33	NLT 32/ 3V/ Z33/ 45 HLT 32/ 3V/ Z33/ 45
		40	11,0	20,0	NLT 40/ 3E/ Z33 HLT 40/ 3E/ Z33	NLT 40/ 3ZM/ Z33 HLT 40/ 3ZM/ Z33	NLT 40/ 3V/ Z33/ 45 HLT 40/ 3V/ Z33/ 45
		63	18,5	22,5	NLT 63/ 3E/ Z33 HLT 63/ 3E/ Z33	NLT 63/ 3ZM/ Z33 HLT 63/ 3ZM/ Z33	NLT 63/ 3V/ Z33/ 45 HLT 63/ 3V/ Z33/ 45
		80	22,0	30,0	NLT 80/ 3E/ Z33 HLT 80/ 3E/ Z33	NLT 80/ 3ZM/ Z33 HLT 80/ 3ZM/ Z33	NLT 80/ 3V/ Z33/ 45 HLT 80/ 3V/ Z33/ 45
		100	30,0	37,0	NLT 100/ 3E/ Z33 HLT 100/ 3E/ Z33		NLT 100/ 3V/ Z33/ 45 HLT 100/ 3V/ Z33/ 45
		125	37,0	45,0	NLT 125/ 3E/ Z33 HLT 125/ 3E/ Z33		NLT 125/ 3V/ Z33/ 45 HLT 125/ 3V/ Z33/ 45
		180	75,0	90,5	NLT 180/ 3E/ Z20 HLT 180/ 3E/ Z20		NLT 180/ 3V/ Z20/ 65 HLT 180/ 3V/ Z20/ 65
		250	110,0	132,0	NLT 250/ 3E/ Z20 HLT 250/ 3E/ Z20		NLT 250/ 3V/ Z20/ 65 HLT 250/ 3V/ Z20/ 65
	4-pole	16	5,5	7,5	E NLT 16/ 4E/ Z33 HLT 16/ 4E/ Z33	ZM NLT 16/ 4ZM/ Z33 HLT 16/ 4ZM/ Z33	V NLT 16/ 4V/ Z33/ 45 HLT 16/ 4V/ Z33/ 45
		25	7,5	9,5	NLT 25/ 4E/ Z33 HLT 25/ 4E/ Z33	NLT 25/ 4ZM/ Z33 HLT 25/ 4ZM/ Z33	NLT 25/ 4V/ Z33/ 45 HLT 25/ 4V/ Z33/ 45
		32	9,5	11,5	NLT 32/ 4E/ Z33 HLT 32/ 4E/ Z33	NLT 32/ 4ZM/ Z33 HLT 32/ 4ZM/ Z33	NLT 32/ 4V/ Z33/ 45 HLT 32/ 4V/ Z33/ 45
		40	11,0	20,0	NLT 40/ 4E/ Z33 HLT 40/ 4E/ Z33	NLT 40/ 4ZM/ Z33 HLT 40/ 4ZM/ Z33	NLT 40/ 4V/ Z33/ 45 HLT 40/ 4V/ Z33/ 45
		63	18,5	22,5	NLT 63/ 4E/ Z33 HLT 63/ 4E/ Z33	NLT 63/ 4ZM/ Z33 HLT 63/ 4ZM/ Z33	NLT 63/ 4V/ Z33/ 45 HLT 63/ 4V/ Z33/ 45
		80	22,0	30,0	NLT 80/ 4E/ Z33 HLT 80/ 4E/ Z33	NLT 80/ 4ZM/ Z33 HLT 80/ 4ZM/ Z33	NLT 80/ 4V/ Z33/ 45 HLT 80/ 4V/ Z33/ 45
		100	30,0	37,0	NLT 100/ 4E/ Z33 HLT 100/ 4E/ Z33		NLT 100/ 4V/ Z33/ 45 HLT 100/ 4V/ Z33/ 45
		125	37,0	45,0	NLT 125/ 4E/ Z33 HLT 125/ 4E/ Z33		NLT 125/ 4V/ Z33/ 45 HLT 125/ 4V/ Z33/ 45
		180	75,0	90,5	NLT 180/ 4E/ Z20 HLT 180/ 4E/ Z20		NLT 180/ 4V/ Z20/ 65 HLT 180/ 4V/ Z20/ 65
		250	110,0	132,0	NLT 250/ 4E/ Z20 HLT 250/ 4E/ Z20		NLT 250/ 4V/ Z20/ 65 HLT 250/ 4V/ Z20/ 65
	6-pole	16	5,5	7,5	E NLT 20/ 6E/ Z33 HLT 20/ 6E/ Z33		V NLT 20/ 6V/ Z33/ 45 HLT 20/ 6V/ Z33/ 45
		25	7,5	9,5	NLT 25/ 6E/ Z33 HLT 25/ 6E/ Z33		NLT 25/ 6V/ Z33/ 45 HLT 25/ 6V/ Z33/ 45
		32	9,5	11,5	NLT 32/ 6E/ Z33 HLT 32/ 6E/ Z33		NLT 32/ 6V/ Z33/ 45 HLT 32/ 6V/ Z33/ 45
		40	11,0	20,0	NLT 40/ 6E/ Z33 HLT 40/ 6E/ Z33		NLT 40/ 6V/ Z33/ 45 HLT 40/ 6V/ Z33/ 45
		63	18,5	22,5	NLT 63/ 6E/ Z33 HLT 63/ 6E/ Z33		NLT 63/ 6V/ Z33/ 45 HLT 63/ 6V/ Z33/ 45
		80	22,0	30,0	NLT 80/ 6E/ Z33 HLT 80/ 6E/ Z33		NLT 80/ 6V/ Z33/ 45 HLT 80/ 6V/ Z33/ 45
		100	30,0	37,0	NLT 100/ 6E/ Z33 HLT 100/ 6E/ Z33		NLT 100/ 6V/ Z33/ 45 HLT 100/ 6V/ Z33/ 45
		125	37,0	45,0	NLT 125/ 6E/ Z33 HLT 125/ 6E/ Z33		NLT 125/ 6V/ Z33/ 45 HLT 125/ 6V/ Z33/ 45
		180	75,0	90,5	NLT 180/ 6E/ Z20 HLT 180/ 6E/ Z20		NLT 180/ 6V/ Z20/ 65 HLT 180/ 6V/ Z20/ 65
		250	110,0	132,0	NLT 250/ 6E/ Z20 HLT 250/ 6E/ Z20		NLT 250/ 6V/ Z20/ 65 HLT 250/ 6V/ Z20/ 65

ON LOAD CHANGE-OVER-SWITCHES

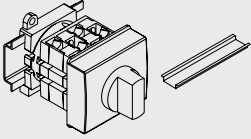
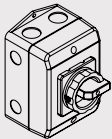
DIN-Railmounting	Maintenance switch, plastic enclosed	IP65
		
Type	Type	
T NLT 16/ 3T/ Z20 HLT 16/ 3T/ Z20	RLT 16/ 3PM-D1/ Z33	
NLT 25/ 3T/ Z20 HLT 25/ 3T/ Z20	RLT 25/ 3PM-D1/ Z33	
NLT 32/ 3T/ Z20 HLT 32/ 3T/ Z20	RLT 32/ 3PM-D1/ Z33	
NLT 40/ 3T/ Z20 HLT 40/ 3T/ Z20	RLT 40/ 3PM-D1/ Z33	
NLT 63/ 3T/ Z20 HLT 63/ 3T/ Z20	RLT 63/ 3PM-D2/ Z33	
NLT 80/ 3T/ Z20 HLT 80/ 3T/ Z20	RLT 80/ 3PM-D2/ Z33	
NLT 100/ 3T/ Z20 HLT 100/ 3T/ Z20	RLT 100/ 3PM-D3/ Z33	
NLT 125/ 3T/ Z20 HLT 125/ 3T/ Z20	RLT 125/ 3PM-D3/ Z33	
	RLT 180/ 3K4/ Z20	
	RLT 250/ 3K4/ Z20	

Connection diagram

3-pole

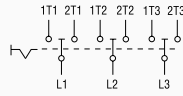

4-pole

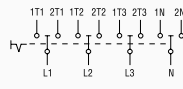

Thermal rated current I_{th} (in A)	Rated perf. at 3x400V (in kW)		4-Hole mounting		DIN-Railmounting	
	I_{th}	AC3	AC23	Type	Type	Type
25	7,5	9,5	E	ULT 25/ 3E	T	ULT 25/ 3T
32	9,5	11,5		ULT 32/ 3E		ULT 32/ 3T
40	11,0	20,0		ULT 40/ 3E		ULT 40/ 3T
63	18,5	22,5		ULT 63/ 3E		ULT 63/ 3T
80	22,0	30,0		ULT 80/ 3E		ULT 80/ 3T
100	30,0	37,0		ULT 100/ 3E		ULT 100/ 3T
125	37,0	45,0		ULT 125/ 3E		ULT 125/ 3T
180	75,0	90,5		ULT 180/ 3E		
250	110,0	132,0		ULT 250/ 3E		
25	7,5	9,5	E	ULT 25/ 4E	T	ULT 25/ 4T
32	9,5	11,5		ULT 32/ 4E		ULT 32/ 4T
40	11,0	20,0		ULT 40/ 4E		ULT 40/ 4T
63	18,5	22,5		ULT 63/ 4E		ULT 63/ 4T
80	22,0	30,0		ULT 80/ 4E		ULT 80/ 4T
100	30,0	37,0		ULT 100/ 4E		ULT 100/ 4T
125	37,0	45,0		ULT 125/ 4E		ULT 125/ 4T
180	75,0	90,5		ULT 180/ 4E		
250	110,0	132,0		ULT 250/ 4E		

T NLT 16/ 4T/ Z20 HLT 16/ 4T/ Z20	RLT 16/ 4PM-D1/ Z33
NLT 25/ 4T/ Z20 HLT 25/ 4T/ Z20	RLT 25/ 4PM-D1/ Z33
NLT 32/ 4T/ Z20 HLT 32/ 4T/ Z20	RLT 32/ 4PM-D1/ Z33
NLT 40/ 4T/ Z20 HLT 40/ 4T/ Z20	RLT 40/ 4PM-D1/ Z33
NLT 63/ 4T/ Z20 HLT 63/ 4T/ Z20	RLT 63/ 4PM-D2/ Z33
NLT 80/ 4T/ Z20 HLT 80/ 4T/ Z20	RLT 80/ 4PM-D2/ Z33
NLT 100/ 4T/ Z20 HLT 100/ 4T/ Z20	RLT 100/ 4PM-D3/ Z33
NLT 125/ 4T/ Z20 HLT 125/ 4T/ Z20	RLT 125/ 4PM-D3/ Z33
	RLT 180/ 4K4/ Z20
	RLT 250/ 4K4/ Z20

ADDITIONAL- AND AUXILIARY CONTACTS

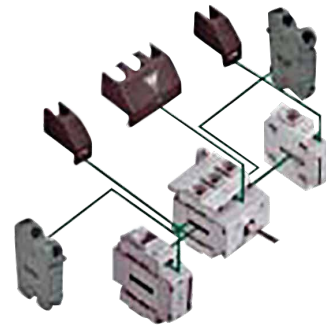

ADDITIONAL CONTACTS

Switch size	Constr. form E+ZM		Constr. form V+T	
LT 16, 20A, 25A	NVG	20AE	NVG	20AV
LT 25-40	NVG	40E	NVG	40V
LT 63-80	NVG	80E	NVG	80V
LT 100-125	NVG	125E	NVG	125V
LT 180-250	NVG	250E	NVG	250V
LT 16, 20A, 25A	NGG	20AE	NGG	20AV
LT 25-40	NGG	40E	NGG	40V
LT 63-80	NGG	80E	NGG	80V
LT 100-125	NGG	125E	NGG	125V
LT 180-250	NGG	250E	NGG	250V
LT 16, 20A, 25A	N / PE	20AE	N / PE	20AV
LT 25-40	N / PE	40E	N / PE	40V
LT 63-80	N / PE	80E	N / PE	80V
LT 100-125	N / PE	125E	N / PE	125V
LT 180-250	N / PE	250E	N / PE	250V

T NLT 20/ 6T/ Z20 HLT 20/ 6T/ Z20	RLT 20/ 6PM-D1/ Z33	Neutral Pole (early make) 
NLT 25/ 6T/ Z20 HLT 25/ 6T/ Z20	RLT 25/ 6PM-D2/ Z33	
NLT 32/ 6T/ Z20 HLT 32/ 6T/ Z20	RLT 32/ 6PM-D2/ Z33	Neutral Pole (simultaneous make) 
NLT 40/ 6T/ Z20 HLT 40/ 6T/ Z20	RLT 40/ 6PM-D2/ Z33	
NLT 63/ 6T/ Z20 HLT 63/ 6T/ Z20	RLT 63/ 6PM-D3/ Z33	Neutral Pole (solid neutral) 
NLT 80/ 6T/ Z20 HLT 80/ 6T/ Z20	RLT 80/ 6PM-D3/ Z33	
NLT 100/ 6T/ Z20 HLT 100/ 6T/ Z20	RLT 100/ 6PM-D3/ Z33	
NLT 125/ 6T/ Z20 HLT 125/ 6T/ Z20	RLT 125/ 6PM-D3/ Z33	
	RLT 180/ 6K4/ Z20	
	RLT 250/ 6K4/ Z20	

AUXILIARY CONTACTS (1NO + 1NC)

LT 16-250	HE11	HV11
-----------	------	------

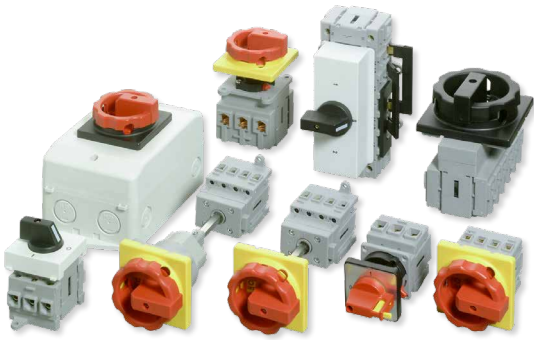

	I_{th} A	AC23 kW (3x400V)	AC3 kW	U V	connection cross mm ²
LO16	16	7,5	5,5	690	25
LO25	25	9,5	7,5	690	25
LO32	32	11,5	9,5	690	25
LO40	40	20,0	11,0	690	25
LO63	63	22,0	18,5	690	25
H11	10			240	4

Other configurations and sizes on request

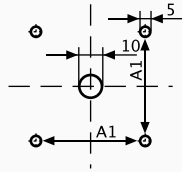
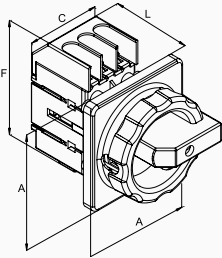

E

TYPE	A	A1	C 3pol	C 4pol	C 6pol	F	L
LO16	66	48	36	49	72	73	54
LO25	66	48	36	49	72	73	54
LO32	66	48	36	49	72	73	54
LO40	66	48	36	49	72	73	54
LO63	66	48	36	49	72	73	54

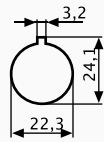
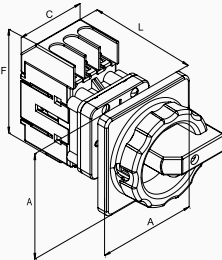

ZM

TYPE	A	A1	C 3pol	C 4pol	C 6pol	F	L
LO16	66	-	36	49	-	73	77
LO25	66	-	36	49	-	73	77
LO32	66	-	36	49	-	73	77
LO40	66	-	36	49	-	73	77
LO63	66	-	36	49	-	73	77

IP65

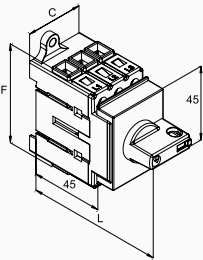

T

TYPE	A	A1	C 3pol	C 4pol	C 6pol	F	L
LO16	66	-	36	49	72	73	77
LO25	66	-	36	49	72	73	77
LO32	66	-	36	49	72	73	77
LO40	66	-	36	49	72	73	77
LO63	66	-	36	49	72	73	77

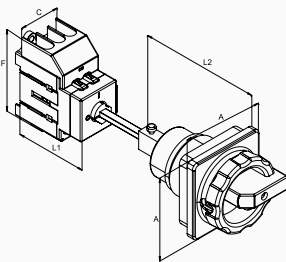

V/Z33/Z45

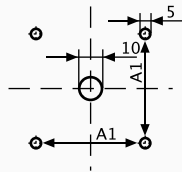

TYPE	A	A1	C 3pol	C 4pol	C 6pol	F	L1	L2
LO16	66	48	36	49	72	73	66	77
LO25	66	48	36	49	72	73	66	77
LO32	66	48	36	49	72	73	66	77
LO40	66	48	36	49	72	73	66	77
LO63	66	48	36	49	72	73	66	77

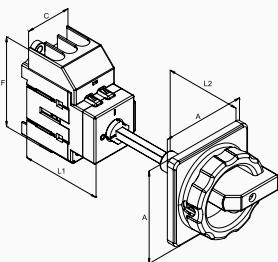

V/Z33/Z71

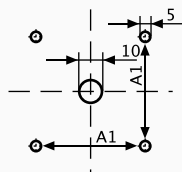

TYPE	A	A1	C 3pol	C 4pol	C 6pol	F	L1	L2
LO16	66	48	36	49	72	73	66	28
LO25	66	48	36	49	72	73	66	28
LO32	66	48	36	49	72	73	66	28
LO40	66	48	36	49	72	73	66	28
LO63	66	48	36	49	72	73	66	28

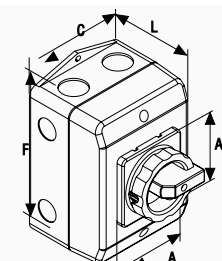

Enclosures

TYPE	A	C	F	L	Knockouts
PM-D1/Z33	66	100	140	81	4 x M25, 4 x M20
PM-D2/Z33	66	146	176	104	4 x M32/40, 4 x M20

Sheet metal enclosures and EMC-accessories

IP65

ON LOAD SWITCHES LO

Connection diagram

Connection diagram	Thermal rated current I_{th} (in A)	Rated perf. at 3x400V (in kW)	Rated perf. at 3x400V (in kW)	4-Hole mounting		Central mounting		Base mounting	
				Type	Type	Type	Type		
<p>3-pole</p>	16	5,5	7,5	E	NLO 16 / 3E/ Z33 HLO 16 / 3E/ Z33	ZM	NLO 16/ 3ZM/ Z33 HLO 16/ 3ZM/ Z33	V	NLO 16/ 3V/ Z33/ 71 HLO 16/ 3V/ Z33/ 71
	25	7,5	9,5		NLO 25/ 3E/ Z33 HLO 25/ 3E/ Z33		NLO 25/ 3ZM/ Z33 HLO 25/ 3ZM/ Z33		NLO 25/ 3V/ Z33/ 71 HLO 25/ 3V/ Z33/ 71
	32	9,5	11,5		NLO 32/ 3E/ Z33 HLO 32/ 3E/ Z33		NLO 32/ 3ZM/ Z33 HLO 32/ 3ZM/ Z33		NLO 32/ 3V/ Z33/ 71 HLO 32/ 3V/ Z33/ 71
	40	11,0	20,0		NLO 40/ 3E/ Z33 HLO 40/ 3E/ Z33		NLO 40/ 3ZM/ Z33 HLO 40/ 3ZM/ Z33		NLO 40/ 3V/ Z33/ 71 HLO 40/ 3V/ Z33/ 71
	63	18,5	22,5		NLO 63/ 3E/ Z33 HLO 63/ 3E/ Z33		NLO 63/ 3ZM/ Z33 HLO 63/ 3ZM/ Z33		NLO 63/ 3V/ Z33/ 71 HLO 63/ 3V/ Z33/ 71
<p>4-pole</p>	16	5,5	7,5	E	NLO 16/ 4E/ Z33 HLO 16/ 4E/ Z33	ZM	NLO 16/ 4ZM/ Z33 HLO 16/ 4ZM/ Z33	V	NLO 16/ 4V/ Z33/ 71 HLO 16/ 4V/ Z33/ 71
	25	7,5	9,5		NLO 25/ 4E/ Z33 HLO 25/ 4E/ Z33		NLO 25/ 4ZM/ Z33 HLO 25/ 4ZM/ Z33		NLO 25/ 4V/ Z33/ 71 HLO 25/ 4V/ Z33/ 71
	32	9,5	11,5		NLO 32/ 4E/ Z33 HLO 32/ 4E/ Z33		NLO 32/ 4ZM/ Z33 HLO 32/ 4ZM/ Z33		NLO 32/ 4V/ Z33/ 71 HLO 32/ 4V/ Z33/ 71
	40	11,0	20,0		NLO 40/ 4E/ Z33 HLO 40/ 4E/ Z33		NLO 40/ 4ZM/ Z33 HLO 40/ 4ZM/ Z33		NLO 40/ 4V/ Z33/ 71 HLO 40/ 4V/ Z33/ 71
	63	18,5	22,5		NLO 63/ 4E/ Z33 HLO 63/ 4E/ Z33		NLO 63/ 4ZM/ Z33 HLO 63/ 4ZM/ Z33		NLO 63/ 4V/ Z33/ 71 HLO 63/ 4V/ Z33/ 71
<p>6-pole</p>	16	5,5	7,5	E	NLO 16/ 6E/ Z33 HLO 16/ 6E/ Z33			V	NLO 16/ 6V/ Z33/ 71 HLO 16/ 6V/ Z33/ 71
	25	7,5	9,5		NLO 25/ 6E/ Z33 HLO 25/ 6E/ Z33				NLO 25/ 6V/ Z33/ 71 HLO 25/ 6V/ Z33/ 71
	32	9,5	11,5		NLO 32/ 6E/ Z33 HLO 32/ 6E/ Z33				NLO 32/ 6V/ Z33/ 71 HLO 32/ 6V/ Z33/ 71
	40	11,0	20,0		NLO 40/ 6E/ Z33 HLO 40/ 6E/ Z33				NLO 40/ 6V/ Z33/ 71 HLO 40/ 6V/ Z33/ 71
	63	18,5	22,5		NLO 63/ 6E/ Z33 HLO 63/ 6E/ Z33				NLO 63/ 6V/ Z33/ 71 HLO 63/ 6V/ Z33/ 71

ON LOAD CHANGE-OVER-SWITCHES

Connection diagram

Connection diagram	Thermal rated current I_{th} (in A)	Rated perf. at 3x400V (in kW)	Rated perf. at 3x400V (in kW)	4-Hole mounting		DIN-Railmounting	
				Type	Type	Type	Type
<p>3-pole</p>	25	7,5	9,5	E	ULO 25/ 3E	T	ULO 25/ 3T
	32	9,5	11,5		ULO 32/ 3E		ULO 32/ 3T
	40	11,0	20,0		ULO 40/ 3E		ULO 40/ 3T
	63	18,5	22,5		ULO 63/ 3E		ULO 63/ 3T
<p>4-pole</p>	25	7,5	9,5	E	ULO 25/ 4E	T	ULO 25/ 4T
	32	9,5	11,5		ULO 32/ 4E		ULO 32/ 4T
	40	11,0	20,0		ULO 40/ 4E		ULO 40/ 4T
	63	18,5	22,5		ULO 63/ 4E		ULO 63/ 4T

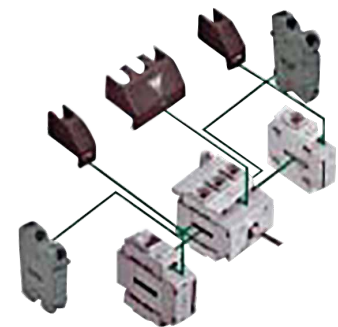

DIN-Railmounting

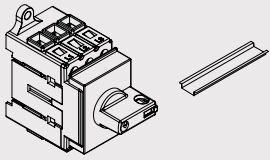

Maintenance switch, plastic enclosed

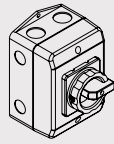

IP65

Type

Type

T	NLO 16/ 3T/ Z20C HLO 16/ 3T/ Z20C	RLO 16/ 3PM-D1/ Z33
	NLO 25/ 3T/ Z20C HLO 25/ 3T/ Z20C	RLO 25/ 3PM-D1/ Z33
	NLO 32/ 3T/ Z20C HLO 32/ 3T/ Z20C	RLO 32/ 3PM-D1/ Z33
	NLO 40/ 3T/ Z20C HLO 40/ 3T/ Z20C	RLO 40/ 3PM-D1/ Z33
	NLO 63/ 3T/ Z20C HLO 63/ 3T/ Z20C	RLO 63/ 3PM-D2/ Z33

T	NLO 16/ 4T/ Z20C HLO 16/ 4T/ Z20C	RLO 16/ 4PM-D1 /Z33
	NLO 25/ 4T/ Z20C HLO 25/ 4T/ Z20C	RLO 25/ 4PM-D1 /Z33
	NLO 32/ 4T/ Z20C HLO 32/ 4T/ Z20C	RLO 32/ 4PM-D1/ Z33
	NLO 40/ 4T/ Z20C HLO 40/ 4T/ Z20C	RLO 40/ 4PM-D1 /Z33
	NLO 63/ 4T/ Z20C HLO 63/ 4T/ Z20C	RLO 63/ 4PM-D2 /Z33

T	NLO 16/ 6T/ Z20 HLO 16/ 6T/ Z20	RLO 16/ 6PM-D2/ Z33
	NLO 25/ 6T/ Z20 HLO 25/ 6T/ Z20	RLO 25/ 6PM-D2/ Z33
	NLO 32/ 6T/ Z20 HLO 32/ 6T/ Z20	RLO 32/ 6PM-D2/ Z33
	NLO 40/ 6T/ Z20 HLO 40/ 6T/ Z20	RLO 40/ 6PM-D2/ Z33
	NLO 63/ 6T/ Z20 HLO 63/ 6T/ Z20	RLO 63/ 6PM-D2/ Z33

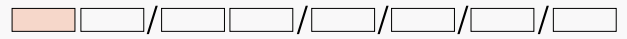

Switch type

NLT/O = Emergency stop switches, colour red/yellow
 HLT/O = Main switches, colour black/black
 ALT/O = DIN-Railmounting with installation cover
 RLTO/O = Maintenance switches, enclosed



Switch size

LO/LT

LT

16	= 16A	7.5 kW	80	= 80A	30.0 kW
25	= 25A	9.5 kW	100	= 100A	37.0 kW
32	= 32A	11.5 kW	125	= 125A	45.0 kW
40	= 40A	11.5 kW	180	= 180A	90.5 kW
63	= 63A	22.5 kW	250	= 250A	132.0 kW



Number of contacts

3, 4, 6 or 8

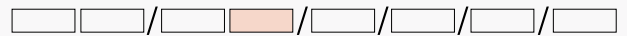

Construction form

E = 4-Hole mounting
 ZM = Central mounting with nut (1 hole)
 V = Base mounting
 T = DIN-Railmounting with installation cover
 PM = Plastic enclosure



Accessories

Z33 = Round padlock device
 Z20C = Padlock handle
 Z1 = Shaft packing IP65 (ZM/PM standard)
 Z44 = Door coupling (construction form V)
 Z71 = Door coupling (construction form V)
 Z45 = Door coupling with door interlock (construction form V)
 Z75 = Door coupling with door interlock and funnel (construction form V)
 X83 = Switch shaft with special dimension (Standard shaft 300 mm)
 EMV = EMC compatible sheet metal (for enclosures)



Auxiliary contacts

H11 = 1NO + 1NC (1Normally open/1Normally closed)

ADDITIONAL- AND AUXILIARY CONTACTS

	Switch size		Constr. form E+ZM		Constr. form V+T	
Neutral pole (early make) 	LO	16	NVGO	16E	NVGO	16V
	LO	25	NVGO	25E	NVGO	25V
	LO	32	NVGO	32E	NVGO	32V
	LO	40	NVGO	40E	NVGO	40V
	LO	63	NVGO	63E	NVGO	63V
Neutral pole (simultaneous make) 	LO	16	NGGO	16E	NGGO	16V
	LO	25	NGGO	25E	NGGO	25V
	LO	32	NGGO	32E	NGGO	32V
	LO	40	NGGO	40E	NGGO	40V
	LO	63	NGGO	63E	NGGO	63V
Neutral pole (solid neutral) 	LO	16	N/PEO	16E	N/PEO	16V
	LO	25	N/PEO	25E	N/PEO	25V
	LO	32	N/PEO	32E	N/PEO	32V
	LO	40	N/PEO	40E	N/PEO	40V
	LO	63	N/PEO	63E	N/PEO	63V
AUXILIARY CONTACTS (1NO + 1NC) 	LO	16-63	HE11		HV11	

Example LT

Emergency/stop switch 7,5 kW (AC-23), 3 poles, base mounting, round padlock and door interlock. The complete order details read:
NLT16/3V/Z33/Z45

Example LO

Emergency/stop switch 7,5 kW (AC-23), 3 poles, base mounting, round padlock and door interlock. The complete order details read:
NLO16/3V/Z33/Z71

Door couplings for base mounted cam- and onload switches

Defeatable door coupling Z39

The coupling interlocks the door in position ON, but it is easily possible to unlock, if wanted, by pushing a small bar. The padlockable handle is included.

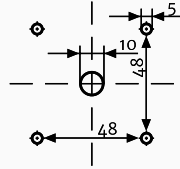
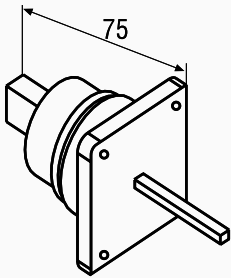

available for group, design

D00	D0	D1	D2	D3
-	V	V	-	-
	LT16- LT25A	LT25- LT40	LT63- LT80	LT100- LT125
	V	V	V	V
		LO		
		V		

Door coupling with compensation, without interlock

This door coupling has a compensation. No interlock in any position.

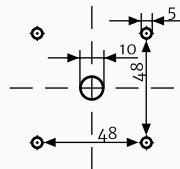
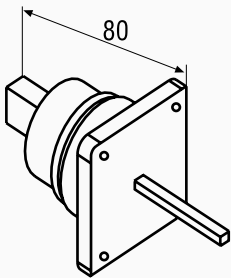

available for group, design

D00	D0	D1	D2	D3
-	V	V	V	-
	LT16- LT25A	LT25- LT40	LT63- LT80	LT100- LT125
	V	V	V	V
		LO		
		V		

Door coupling with compensation, with interlock

This door coupling has a compensation. Interlock in every position except Off-position.

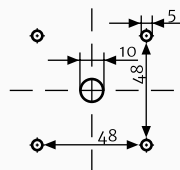
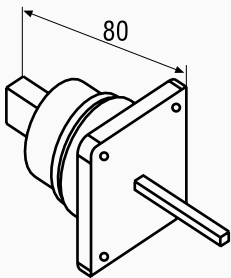

available for group, design

D00	D0	D1	D2	D3
-	V	V	V	-
	LT16- LT25A	LT25- LT40	LT63- LT80	LT100- LT125
	V	V	V	V
		LO		
		V		

Short door coupling with interlock

This short door coupling fits best for very limited mounting depth. IP65!

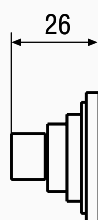

inside panel

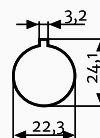

available for group, design

D00	D0	D1	D2	D3
-	V	V	-	-
	div. Gehäuse LT16- LT25A	LT25- LT40	LT63- LT80	LT100- LT125
	V	V	V	V
		LO		
		V		

Possibilities for locking switches

Padlockable handle Z20

For locking with one padlock (D00) with 5 mm thickness or max. two padlocks (D0) or three (D1+D2+D3), hasp thickness 6 mm.

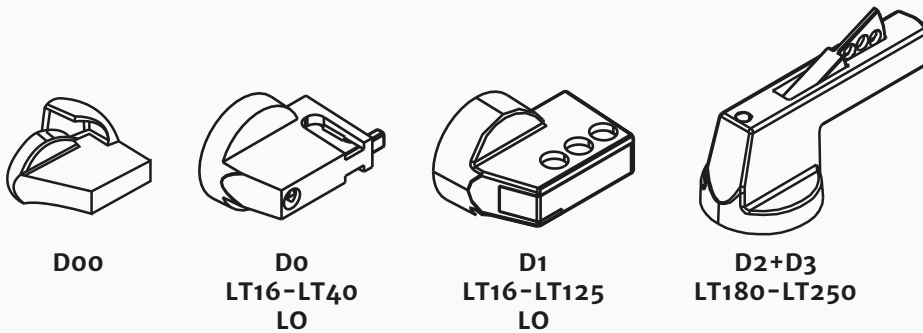

available for group, design

D00	D0	D1	D2	D3
E	E		E	E
ZM	ZM	ZM	V	V
	V	V	V	V
	T	T		
various enclosures				
	LT16-LT40	LT16-LT125	LT180-LT250	
	E	E	E	
	ZM	ZM		
	V	V	V	
	T	T		
	LO	LO		

Cylinder lock Z31

A cylinder lock allows locking certain or all positions.

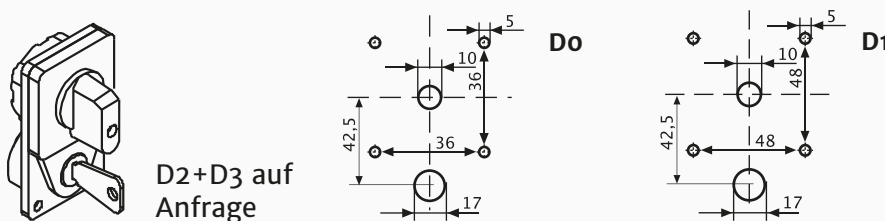

available for group, design

D00	D0	D1	D2	D3
-	E	E	E	E

Key operator device Z32

A key operates the switch. You can choose where the key is removable.

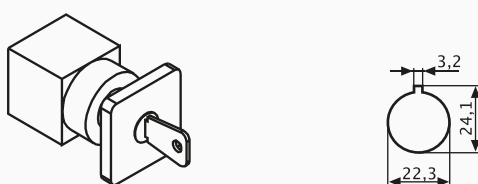

available for group, design

D00	D0	D1	D2	D3
ZM	ZM	ZM	-	-

Round padlockable device Z33

For locking with max. three padlocks, hasp thickness 6 mm (D1) or 8 mm (D2)

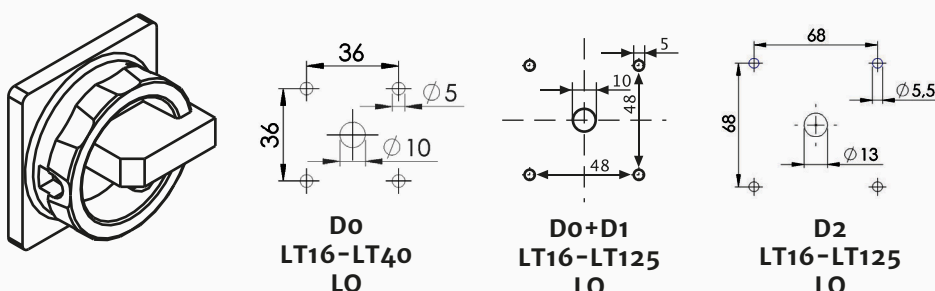

available for group, design

D00	D0	D1	D2	D3
-	E	E		-
	V	ZM	ZM	
	V	V	V	
various enclosures				
	LT16-LT40	LT16-LT125	LT16-LT125	
	E	E	E	
	V	ZM	ZM	
	LO	V	V	
		LO	LO	

Various accessories

Ingress protection IP65 seal systems Z1

Adding /Z1 makes the device IP65 protected. IP65 protection is for construction forms ZM, PLM and PM standard.

IP65 higher protection classes and other construction forms on request.

available for group, design

Doo	Do	D1	D2	D3
E	E	E	E	E
ZM	ZM	ZM	V	V
	V	V	V	V
various enclosures				
LT16- LT25A	LT25- LT40	LT63- LT80	LT100- LT125	LT180- LT250
E	E	E	E	E
ZM	ZM	ZM	V	V
V	V	V	V	V
		LO		

Flat connection Z6

For connection with sockets according to DIN 46247.

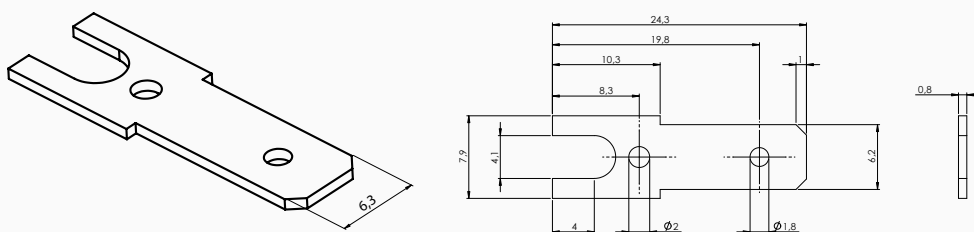

available for group, design

Doo	Do	D1	D2	D3
-	E	E	-	-
	ZM	ZM		
	V	V		
	T	T		

Full terminal shroud Z10

This cover reaches IP42 for the whole switch body from behind.

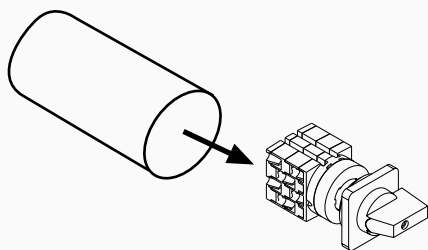

available for group, design

Doo	Do	D1	D2	D3
-	E	E	E	-
	ZM			

Both sided spring return Z55, single sided spring return

The returning positions are 30° angle, the fixed ones are 90°.

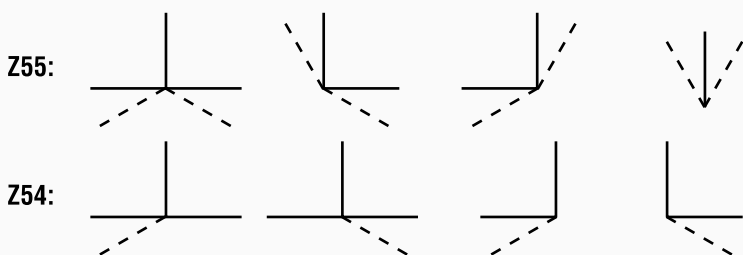

available for group, design

Doo	Do	D1	D2	D3
-	E	E	E	E
	ZM	ZM	V	V
	V	V	V	V
	T	T		

Terminal for control circuits Z58

This item allows connecting a 4 mm wire for a control circuits to a load circuits.

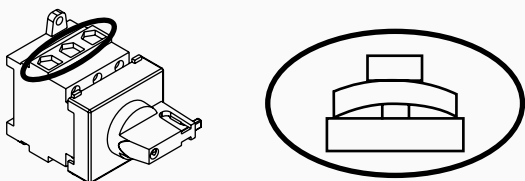

available for group, design

Doo	Do	D1	D2	D3
-	-	-	-	-
	LT25- LT40	LT63- LT80	LT100- LT125	LT180- LT250

Various accessories

Key operator device for DIN standard cylinder lock Z70

Allows integration into locking system. Cylinder not supplied.

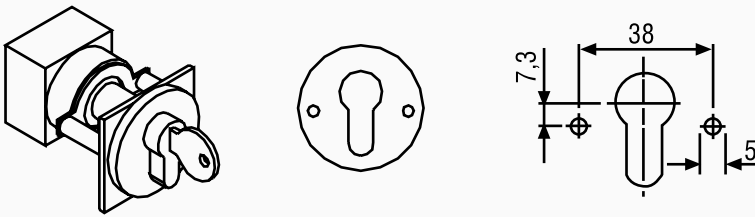

available for group, design

D00	D0/8	D1	D2	D3
-	E	-	-	-

Interlock Z80

Prevents reversing by mistake.

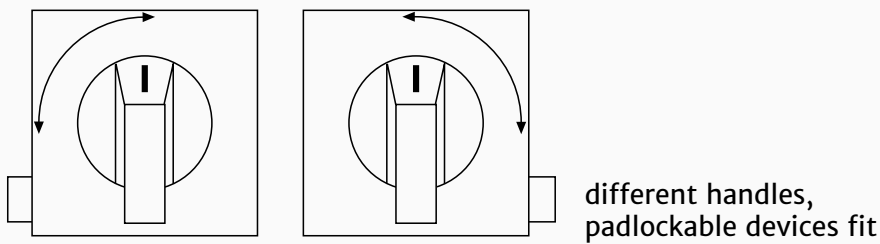

available for group, design

D00	D0	D1	D2	D3
-	-	E	-	-

Protection against accidentally operation Z105

Operation of the switch is only possible by pushing and switching afterwards.

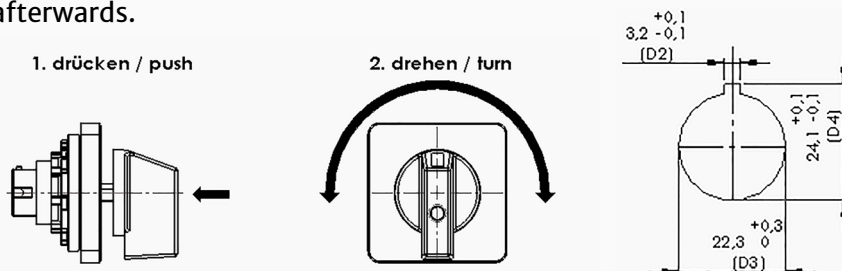

available for group, design

D00	D0	D1	D2	D3
-	ZM	ZM	-	-

Additional frontplates X72 and X72/S0

Additional frontplates allow to mark more.

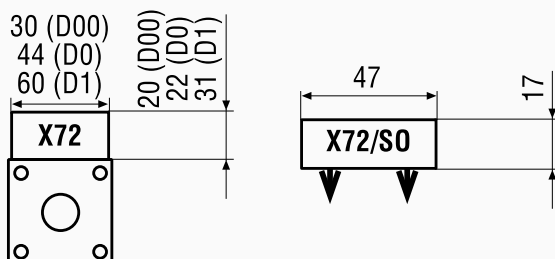

available for group, design

X72				
D00	D0	D1	D2	D3
-	E	E	E	E
	ZM	ZM		
	V	V	V	V
	T	T		

X72/S0

D00	D0	D1	D2	D3
-	-	Z33	Z33	-

Ready-to-Robot X74/R

With this cover the switch can be stored and mounted on the DIN-rail with a robot.

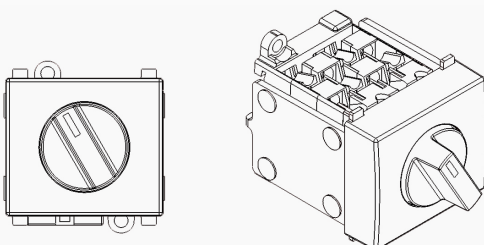

available for group, design

D00	D0	D1	D2	D3
-	T	-	-	-