

SB01 Spring-Applied Brake



Product Overview

SB01 brake is a sort of spring-applied electromagnetic brake and can replace the end-cap of motor to shorten space. The main purpose of SB01 brake is to stop the rotation of the motor shaft instantly.

Its major features are:

- Solid Structure
- Simplified Installation
- Operation with Silent
- Application broadly: The brake enables to cooperate the R&D process of various models or specialized gear.
- Heat Radiation Smoothly: The impurity generated from frictions during operation is blown away by fan easily.
- High Heat-Resistance: The brake coil is covered and encircled by epoxy resin, while mechanical parts are also protected by heat-resistant coating materials.

Structure

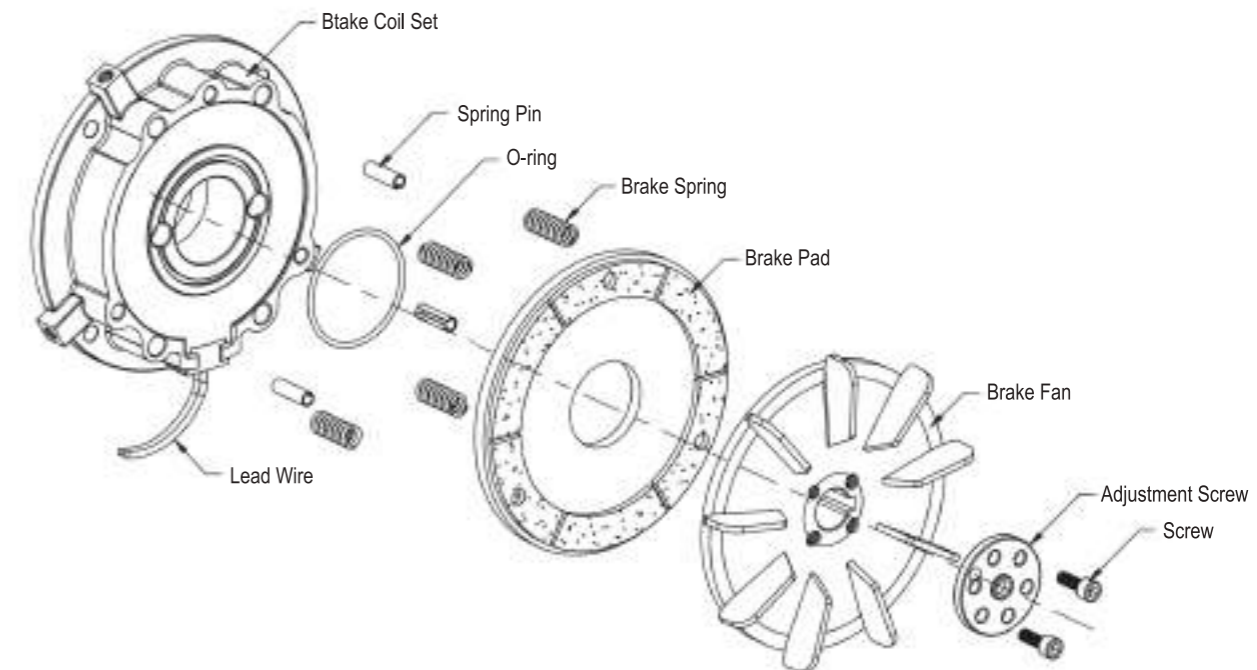

Specifications

Model : SB01

Series	A	B	C	D	E	F	G	H
Matched Motor Frame Size	56	63	71	80	90	100	112	132
Motor Power (KW)	0.09	0.18	0.37	0.75	1.5	2.2	3.7	5.6
Rated Torque (N.M)	0.9	1.8	3.6	7	14	21	35	52.5
Rated Voltage (DC-V)	96	96	96	96	96	96	96	96
Consumption Power (W)	11	17	21	52.5	47	54	54	120
Brake Air Gap (mm)	Standard Value	0.2	0.2	0.25	0.25	0.35	0.35	0.35
	Limited Value	0.4	0.6	0.6	0.7	0.8	0.8	0.8
Weight (Kg)	1.2	1.8	2.9	3.2	5.8	8.3	8.6	12.3

Brake Working Principle

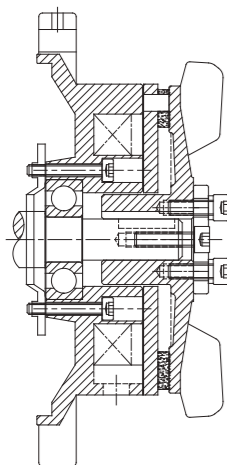

The motor end-cap is replaced by the brake coil set which is installed onto the motor. The armature plate is pushed and to press the brake pad through the compressed brake springs. The brake pad is combined with the motor shaft so that the motor shaft is hold by means of friction between the pad the armature plate.

When the power is connected to the brake coil, the force of the magnetic field is used for torque transmission. Then the armature plate is pulled in axial direction towards the brake coil set so that the brake pad is released and can be free rotation with the motor shaft.



Product Series Selection As Ordering

Model	Size Spec	Frame Materials	Options	Brake Power	Voltage
SB01	D 80	E Cast Iron Contracted	A Standard	C 200%	A DC12V
SB01	A 56	A Iron /Aluimum	A Standard B Hand Release	A 100% B 180% C 200% D 250% E 300%	A DC12V
	B 63	B Iron /Aluimum			B DC24V
	C 71	C Cast Iron			C DC48V
	D 80	D Cast Iron Y-series			D DC96V
	E 90	E Cast Iron Contracted			E DC130V
	F 100				F DC190V
	G 112				G DC220V
	H 132				

SB02 Spring-Applied Brake



Product Overview

SB02 Brake is a practical spring-applied safety brake. Its main purpose is to make the machine stop instantly. However, the selection & application of the SB02 brake needs to fit with the operation of the designed machine requirement, so as to guarantee normal operation of the brake.

Its major features are:

- Solid Structure
- Operation with Silent
- Simplified Installation & Maintenance easily
- The brake coil is covered and encircled by epoxy resin, while mechanical parts are also protected by heat-resistant coating materials so that can enhance the protection capacity of its inner structure.
- Heat Radiation Smoothly: The impurity generated from frictions during operation is blown away by fan easily.
- The brake can be installed onto the motor end-cap directly. (i.e. the motor end-cap is served as the brake surface which shall be composed of steel or cast iron coupled with precisely machining and smoothly in its surface.)

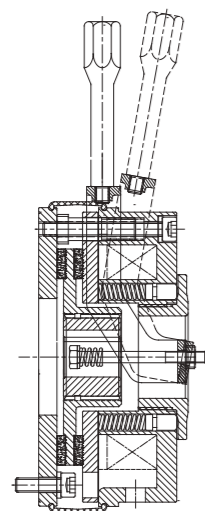

Brake Working Principle

The brake pad is installed onto the motor shaft through the splined gear, coupled with the flange fastened onto the motor end cap. Also, the pad is suppressed by the armature plate through the force of compressed brake springs so that the brake pad is hold between the armature plate and base plate by means of friction.

After installation, an air gap between the brake coil set and the armature plate is kept in specified value. When the power is connected to the brake coil, the force of the magnetic field is used for torque transmission. Then the armature plate is pulled in axial direction towards the brake coil set so that the brake pad is released and can be free rotation with the motor shaft.

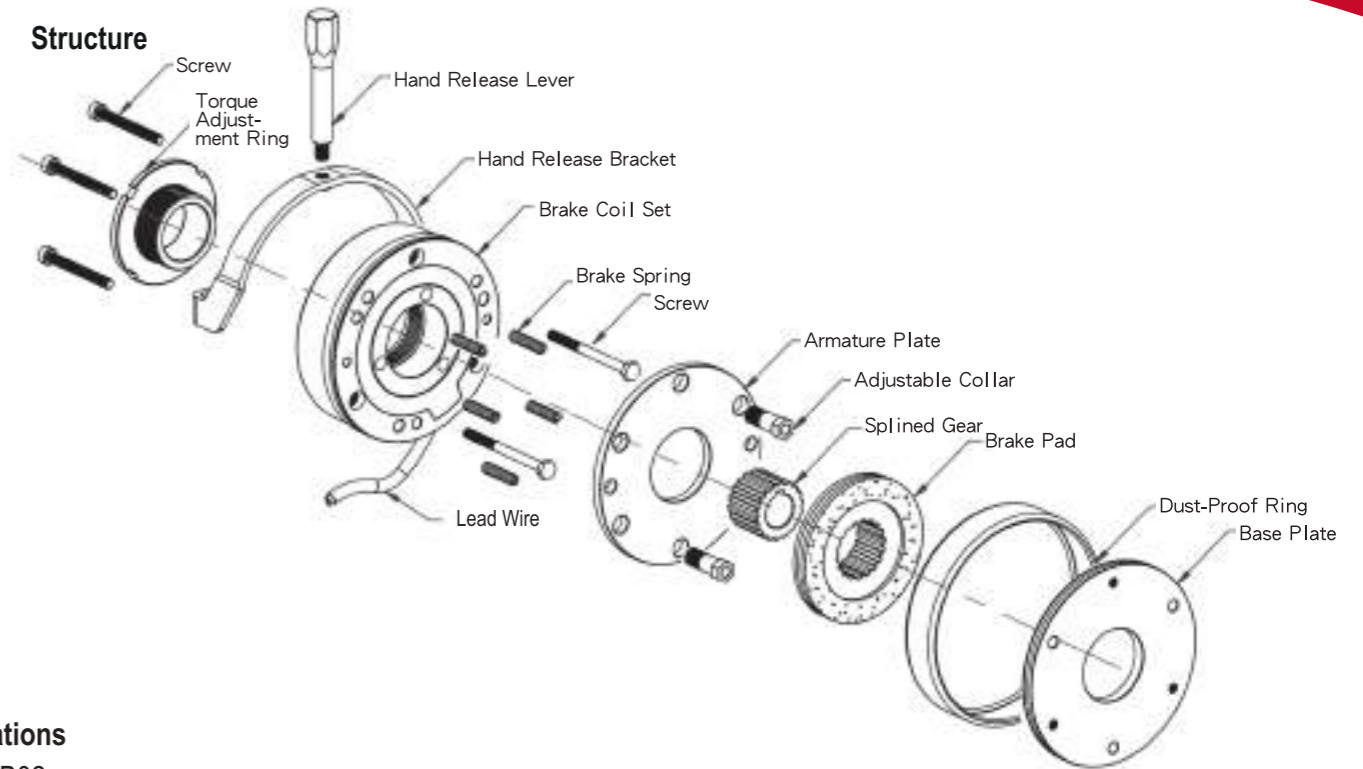

Specifications

Model : SB02

Series	M3	M5	6	8	10	12	14	16	18	20	25
Rated Torque (N.M) ^{Note1}	0.2	0.5	4	8	16	32	60	80	150	260	400
Max. Torque (Max-N.M) ^{Note2}	0.5	1	6	12	23	46	95	125	188	325	500
Rated Voltage(DC-V)	DC96	DC96	DC96	DC96	DC96	DC96	DC96	DC96	DC96	DC96	DC96
Consumption Power (W)	2.2	7.7	20	25	31	40	50	55	85	100	110
Heat Resistant Class	E	E	F	F	F	F	F	F	F	F	F
Max. Rotation Speed (RPM)	5000	5000	3000	3000	3000	3000	3000	3000	2000	2000	2000
Moment of Inertia of Rotation Parts (J·kg.m ²)	4.2×10 ⁻⁶	12.5×10 ⁻⁶	1.5×10 ⁻⁵	6.1×10 ⁻⁵	2×10 ⁻⁴	4.5×10 ⁻⁴	6.3×10 ⁻⁴	1.5×10 ⁻³	2.9×10 ⁻³	7.3×10 ⁻³	2.0×10 ⁻²
Suction Time of Amarture Plate (S)	0.025	0.030	0.045	0.057	0.076	0.115	0.210	0.220	0.270	0.340	0.390
Release Time of Amarture Plate (S)	0.035	0.045	0.025	0.029	0.035	0.045	0.05	0.071	0.033	0.065	0.110

Note 1 : The rated torque is the standard brake torque.
Note 2 : The Max. torque is the holding brake torque.

Product Series Selection As Ordering

Model	Size Spec	Options	Brake Power	Voltage
SB02	14	B Standard	0.06	A DC12V
SB02	M3	A Standard	Customization is available, Please contact with Sunso Industry Ltd.	A DC12V
	M5	B Hand Release		B DC24V
	06	C Hand Release & Dust-proof		C DC48V
	08	D Standard w/o Base Plate		D DC96V
	10	E Hand Release w/o Base Plate		E DC130V
	12	F Hand Release & Dust-proof w/o Base Plate		F DC190V
	14			G DC220V

SB02 Spring-Applied Brake

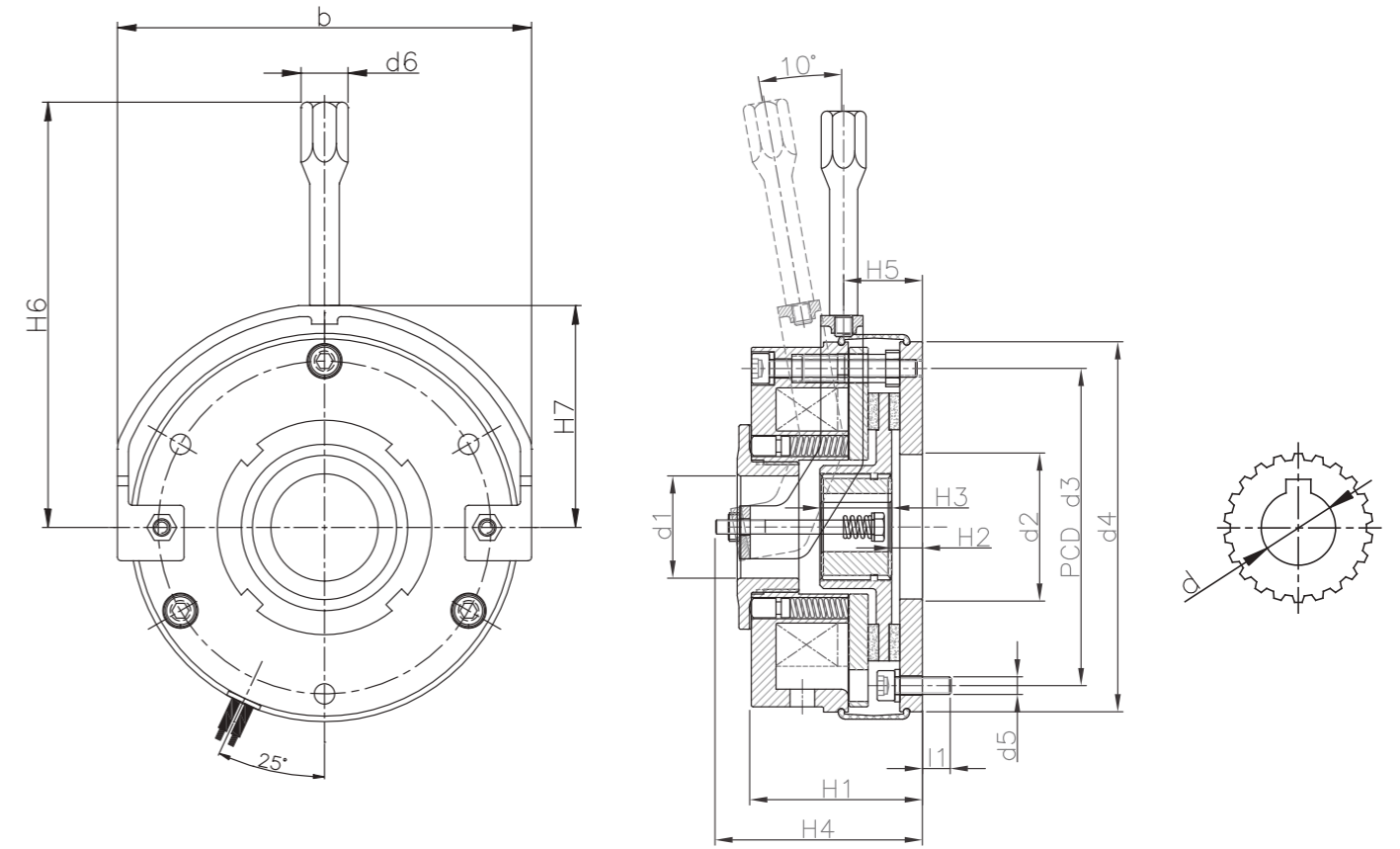
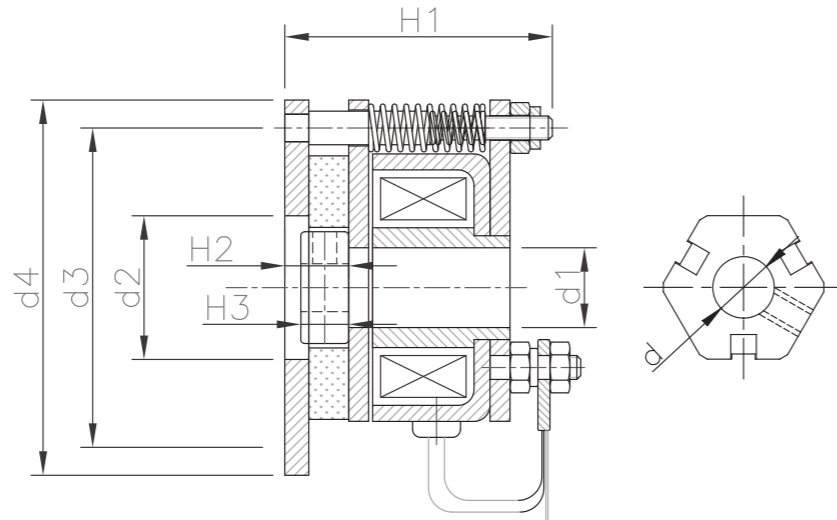
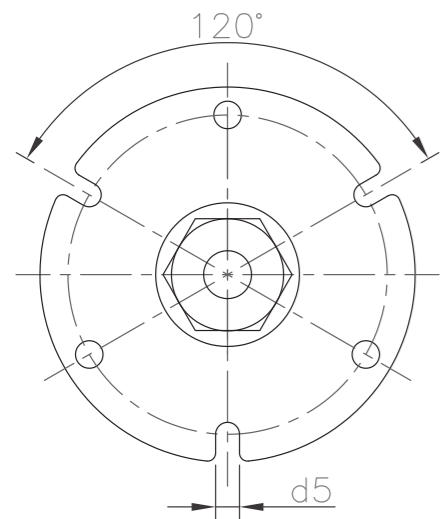

Dimensions

Model : SB02

Unit: mm

Series	M3	M5
b	na	na
d1	10	11.6
d2	18	23
d3	40	55
d4	47	65
d5	3	4.5
H1	35.5	45
H2	8	8
H3	6	8
Weight (Kg)	0.2	0.5
d	6/7	8/9

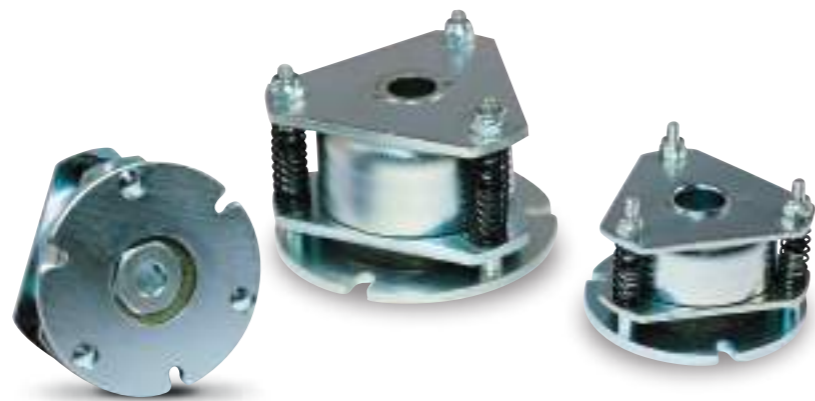

Dimensions

Model : SB02

Unit: mm

Series	06	08	10	12	14	16	18	20	25
b	94	112	143	165	180	207	238	270	318
d1	31	38	44	52	60	70	62	72	102
d2	31	42	44	52	60	70	77	90	120
d3	72	90	112	132	145	170	196	230	278
d4	84	102	130	150	165	190	217	254	302
d5	3xM4	3xM5	3xM6	3xM6	3xM8	3xM8	4xM8	4xM10	4xM10
l1	10	8	16	14	14	13	13	15	16
d6	12.7	12.7	15	15	17	17	22	22	22
H1	43	49	58	69	75	86	94.4	98.3	121.6
H2	7	9	10	11	12	13	13.9	14.9	17
H3	18	20	20	25	30	30	35	40	50
H4	52	59	72	85	90	102	112	110.5	144
H5	21	23	35	39	43	48	52.6	54.5	69.6
H6	107	115	142	162	201	250	267	285	327
H7	52	60	76	89	97	111	128.5	147	189
Weight (Kg)	1.1	1.9	3.8	5.7	8.6	12	15	21.5	33
d	10/11/12/14/15	11/12/14/15/20	11/12/14/15/20	15/17/20/25/27	20/25/30/31	25/30/35/38	30/35/40/45	30/35/40/45	50/60

SB03 Heavy Duty Brake

Product Overview

SB03 Brake is a practical spring-applied safety brake. Its main purpose is to make the machine stop instantly. Also, the integrated design of spline gear can bear much stronger motion torque. However, the selection & application of the SB03 brake needs to fit with the operation of the designed machine requirement, so as to guarantee normal operation of the brake.

Its major features are:

- Integrated design of spline gear.
- Operation with Silent (below 70 dBA).
- Simplified Installation & Maintenance easily.
- The brake coil is covered and encircled by epoxy resin, while mechanical parts are also protected by heat-resistant coating materials so that can enhance the protection capacity of its inner structure.
- Heat radiation rapidly by means of the fan or end cap. The brake can be installed onto the motor end-cap directly. (i.e. the motor end-cap is served as the brake surface which shall be composed of steel or cast iron coupled with precisely machining and smoothly in its surface.

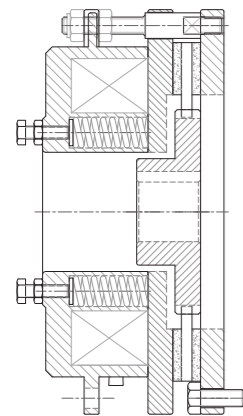
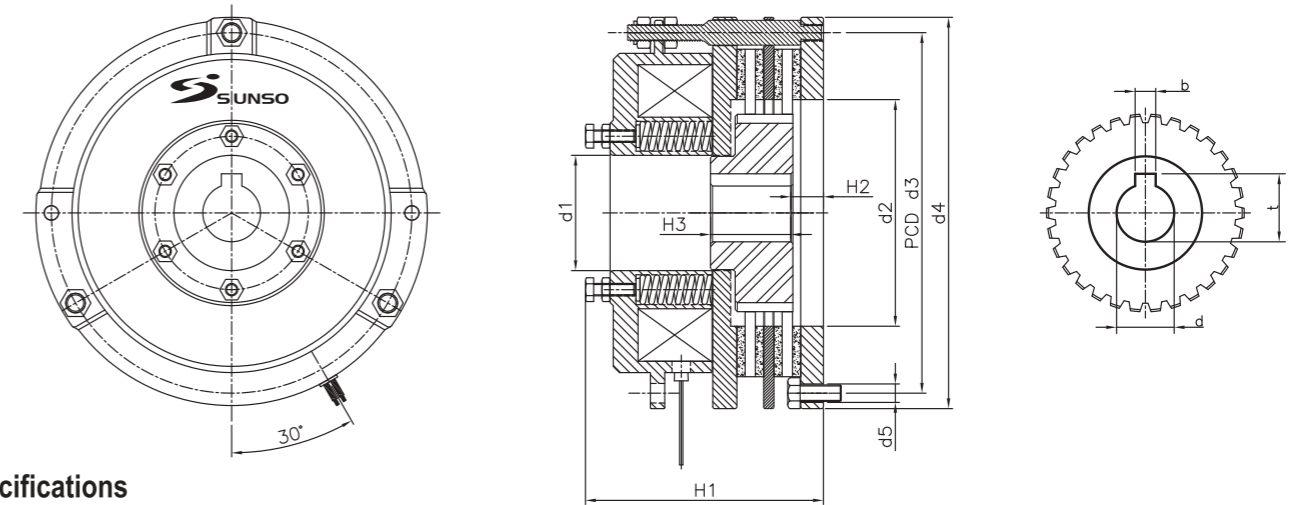
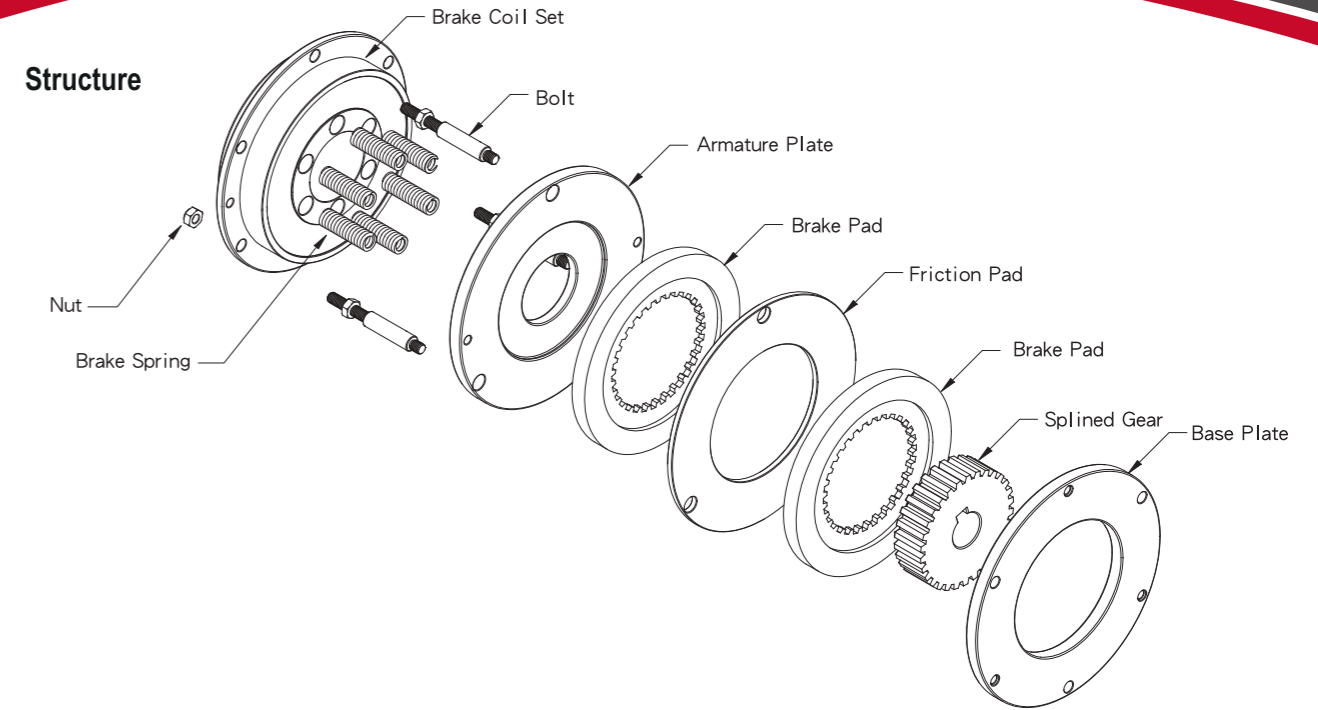

Brake Working Principle

The brake pad is installed onto the motor shaft through the splined gear, coupled with the flange fastened onto the motor end cap. Also, the pad is suppressed by the armature plate through the force of compressed brake springs so that the brake pad is hold between the armature plate and base plate by means of friction.

After installation, an air gap between the brake coil set and the armature plate is kept in specified value. When the power is connected to the brake coil, the force of the magnetic field is used for torque transmission. Then the armature plate is pulled in axial direction towards the brake coil set so that the brake pad is released and can be free rotation with the motor shaft.

Product Series Selection As Ordering

Model	Size Spec	Options	Brake Power	Voltage
SB03	41	A Standard	0.0.6	A DC12V
SB03	41	A Standard B Hand Release	Customerized torque (1~999N.M) is available. Please contact with Sunso Industry Ltd. 0.0.6 means the torque required is 6N.M.	A DC12V
	42			B DC24V
	51			C DC48V
	52			D DC96V
	61			E DC130V
	62			F DC190V
	71			G DC220V
	72			

Specifications

Model : SB03

Series ^{Note1}	41	51	61	71	42	52	62	72
Rated Torque (N.M)	80	180	280	470	160	340	530	880
Max. Torque (Max. N.M)	100	200	300	500	180	360	550	900
b	10	10	10	18	10	10	12	18
t	33	33	50	71	33	33	50	71
d1	56	62	85	105	56	62	85	105
d2	110	125	148	180	110	125	148	180
d3	175	198	252	305	175	198	252	305
d4	190	220	275	340	190	220	275	340
d5	3xM8	3xM10	6xM10	6xM16	3xM8	3xM10	6xM10	6xM16
H1	97	111	116	132	115	131	140	160
H2	13	14	18	16	14	16	21	16
H3	30	30	40	70	40	40	60	70
d(H6)	28/32/35	28/32/35	40/45/50	65	28/32/35	28/32/35	40/45/50	65
Weight (Kg)	8	12	27	100	10	16	34	103

Note 1 : SB03 42/52/62/72 series are equipped with two brake pads.

SB06 Compact Spring-Applied Brake



Product Overview

SB06 brake is a sort of spring-applied electromagnetic brake and can replace the end-cap of motor to shorten the installation space. The main purpose of SB06 brake is to stop the rotation of the motor shaft instantly.

Its major features are:

- Solid Structure
- Simplified Installation
- Operation with Silent
- Heat Radiation Smoothly: The impurity generated from frictions during operation is blown away the fan easily.
- High Heat-Resistance: The brake coil is covered and encircled by epoxy resin, while mechanical parts are also protected by heat-resistant coating materials.
- The customized brake can available to match the requirements of motor or special equipment.

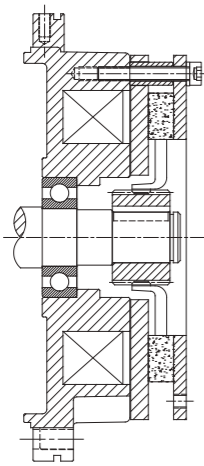

Brake Working Principle

The brake pad is installed onto the motor shaft through the splined gear, coupled with the flange fastened onto the motor end cap. Also, the pad is suppressed by the armature plate through the force of compressed brake springs so that the brake pad is hold between the armature plate and base plate by means of friction.

After installation, an air gap between the brake coil set and the armature plate is kept in specified value. When the power is connected to the brake coil, the force of the magnetic field is used for torque transmission. Then the armature plate is pulled in axial direction towards the brake coil set so that the brake pad is released and can be free rotation with the motor shaft.

Structure

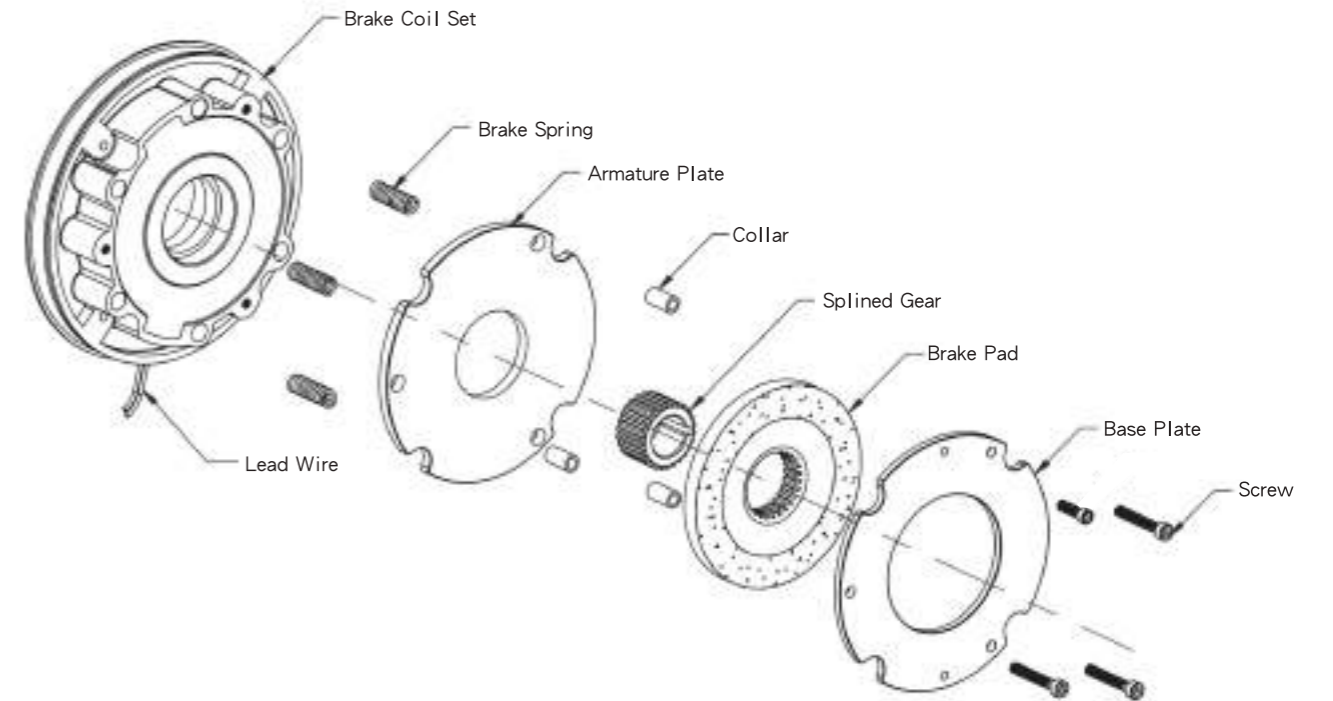

Specifications

Model : SB06

Series	A	B	C	D	E	F	G	H	I
Matched Motor Frame Size	56	63	71	80	90	100	112	132	160
Motor Power (KW)	0.09	0.18	0.37	0.75	1.5	2.2	3.7	5.6	11
Rated Torque (N.M)	1	2	4	8	16	24	40	60	120
Rated Voltage (DC-V)	96	96	96	96	96	96	96	96	96
Consumption Power (W)	11	17	21	52.5	47	54	54	120	110
Brake Air Gap (mm)	Standard Value	0.2	0.2	0.25	0.25	0.35	0.35	0.35	0.35
	Limited Value	0.4	0.6	0.6	0.7	0.8	0.8	0.8	0.8
Weight (Kg)	1.2	1.8	2.9	3.2	5.8	8.3	8.6	12.3	23

Product Series Selection As Ordering

Model	Size Spec	Frame Materials	Options	Brake Power	Voltage
SB06	D 80	E Cast Iron Contracted	A Standard	C 200%	A DC12V
SB06	A 56	A Iron /Aluimum Contracted	A Standard B Hand Release	A 100% B 180% C 200% D 250%	A DC12V
	B 63				B DC24V
	C 71				C DC48V
	D 80	D DC96V			
	E 90	E DC130V			
	F 100	F DC190V			
	G 112	G DC220V			
	H 132				
	I 160				

SB07 AC Brake

CHINA Patent No.

① ZL 2011 1 0321329. 4

② ZL 2011 2 0402476. X

TAIWAN Patent No.

① M 414515

② M 502762



Product Overview

SUNSO SB07 Brake is a totally new design AC spring-applied brake for motor. Its main purpose is to make the machine stop with precisely & instantly by means of hooking up AC current directly so that reduces brake failed because of the rectifier malfunction. In addition, the patented design of dual AC voltages input can match more motion machines' braking power requirement & flexible applications.

Its major features are:

- AC current inputs directly without rectifier
- Dual AC voltage inputs
- Compact structure & smaller installation space
- Modular design and Installation easily
- Operation with silent
- The brake coil is covered and encircled by epoxy resin, while mechanical parts are also galvanized so that the brake can be operated in non-ventilation area.

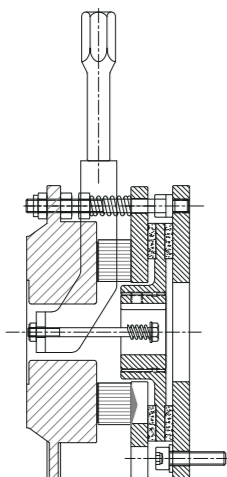

Brake Working Principle

The brake pad is installed onto the motor shaft through the splined gear, coupled with the flange fastened onto the motor end cap. Also, the pad is suppressed by the armature plate through the force of compressed brake springs so that the brake pad is hold between the armature plate and base plate by means of friction.

After installation, an air gap between the brake coil set and the armature plate is kept in specified value. When the power is connected to the brake coil, the force of the magnetic field is used for torque transmission. Then the armature plate is pulled in axial direction towards the brake coil set so that the brake pad is released and can be free rotation with the motor shaft.

Structure

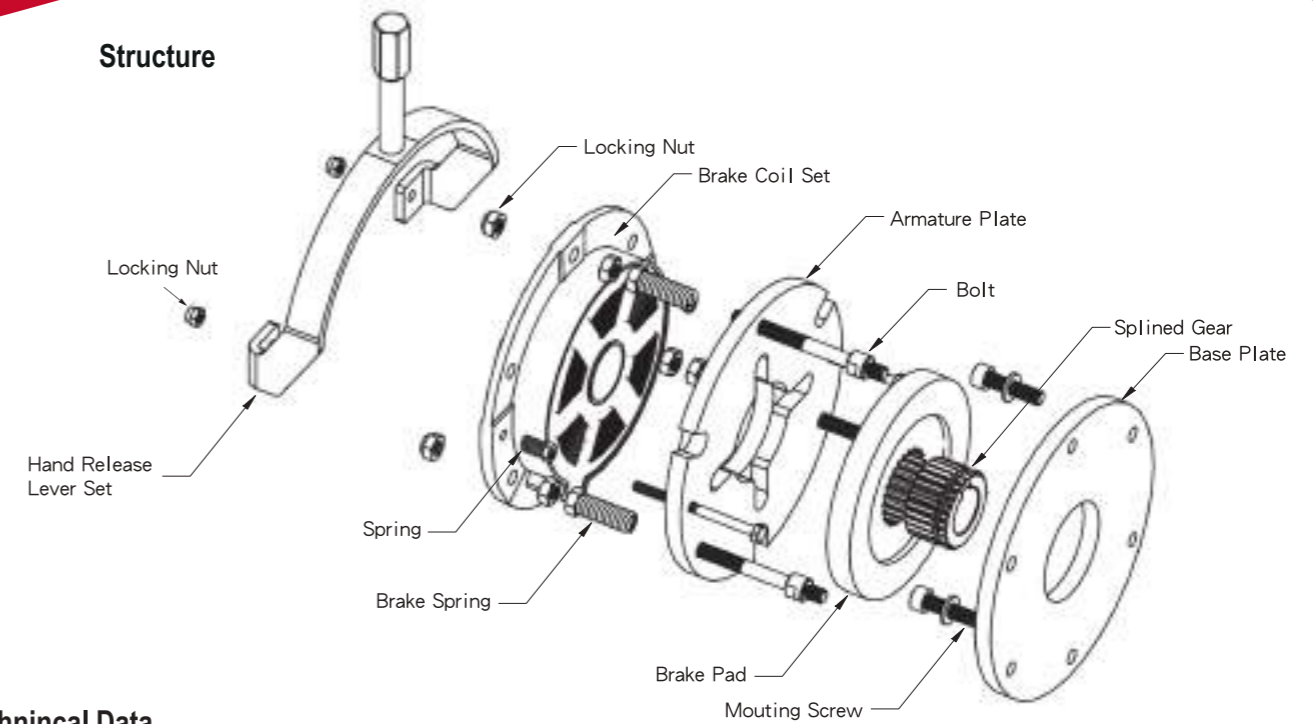

Technical Data

Model : SB07

Series ^{Note1}	08	09	10	11	14	15	16	17	20	21
Static Friction Torque (N.M)	8	14	12	21	35	63	70	126	130	234
Rated Voltage (AC) ^{Note2}	AC220/380	AC220/380	AC220/380	AC220/380	AC220/380	AC220/380	AC220/380	AC220/380	AC220/380	AC220/380
Current (A)	0.11	0.11	0.35	0.35	0.6	0.6	1.2	1.2	2.2	2.2
Suction Voltage (AC)	163V	163V	188V	188V	186V	186V	185V	185V	182V	182V
Release Voltage (AC)	125V	125V	150V	150V	165V	165V	160V	160V	150V	150V
Insulation Class	F	F	F	F	F	F	F	F	F	F
Max. Rotation (RPM)	3000	3000	3000	3000	3000	3000	3000	3000	3000	3000
Moment of Inertia of Rotation Parts (J·kg·m ²)	5.9x10 ⁻⁵	11.8x10 ⁻⁵	2x10 ⁻⁴	4x10 ⁻⁴	6.3x10 ⁻⁴	12.6x10 ⁻⁴	1.5x10 ⁻³	3x10 ⁻³	1.35x10 ⁻²	2.7x10 ⁻²

Note 1 : The series of SB0709/11/15/17/21 are equipped with two brake pads.

Note 2 : Special voltage requirement, please contact with Sunso Industry Ltd.

Product Series Selection As Ordering

Model	Size Spec	Options	Brake Power	Voltage
SB07	10	A Standard	0.0.6	A AC220/380
SB07	08	A Standard B Hand Release	Customization is available, Please contact with Sunso Industry Ltd.	A AC220/380
	09			
	10			
	11			
	14			
	15			
	16			
	17			
	20			
	21			

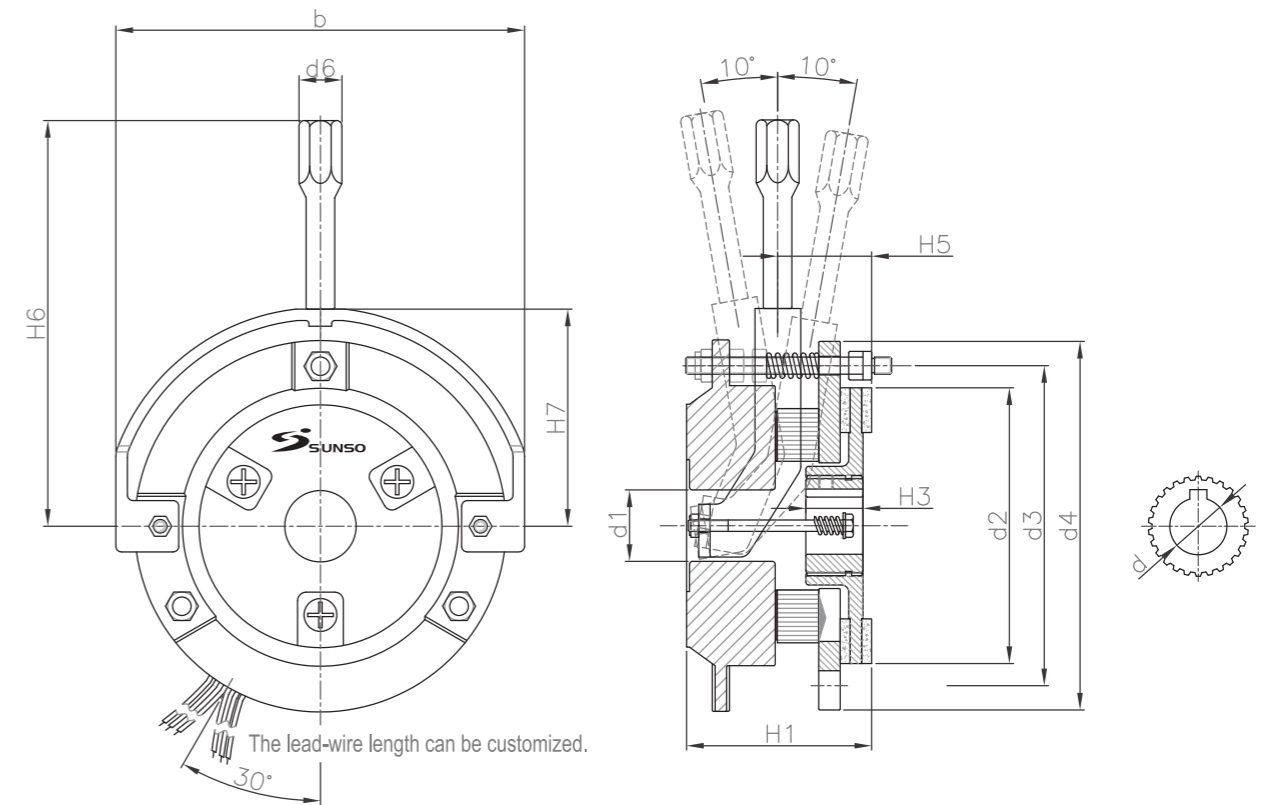
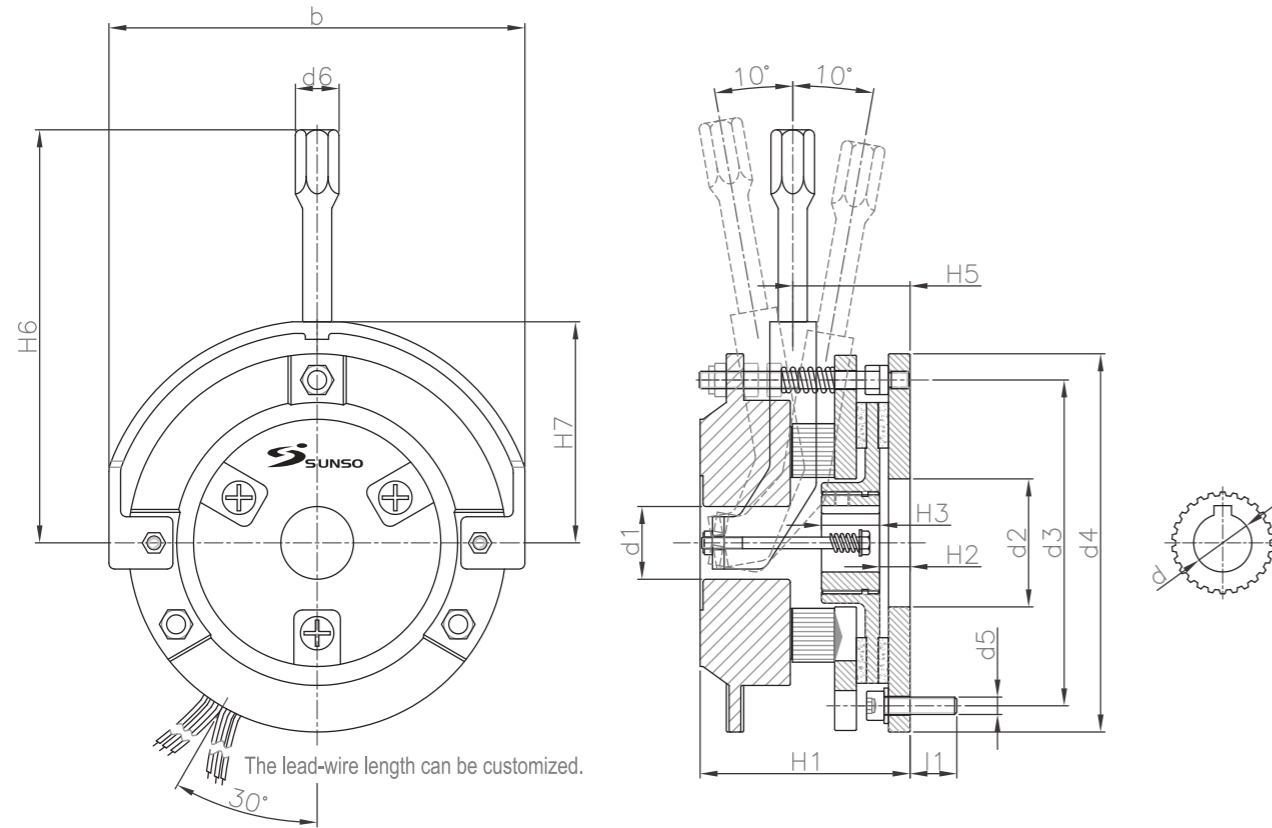

Dimensions

Model : SB07 (Base Plate Included)

Unit: mm

Series	08	09	10	11	14	15	16	17	20	21
b	122	122	143	143	180	180	207	207	255	255
d1	25	25	25	25	35	35	40	40	50	50
d2	40	40	44	44	60	60	70	70	85	85
d3	72/90	72/90	112	112	145	145	170	170	210	210
d4	114	114	130	130	165	165	190	190	240	240
d5	3XM5	3XM5	3XM6	3XM6	3XM8	3XM8	3XM10	3XM10	3XM10	3XM10
d6	12	12	15	15	17	17	17	17	17	17
l1	8	8	12	12	14	14	16	16	16	16
H1	67	83	73	89	94	114	108	127	133	152
H2	7	15	10	11	12	10	13	13	12	15
H3	15/18	15/18	20	20	30	30	30	30	30	30
H5	44	57	38	54	47	66	53	72	111	130
H6	114	114	142	142	201	201	250	250	330	330
H7	64	64	76	76	97	97	111	111	136	136
Weight (Kg)	2.8	3.3	3.9	4.6	8.7	10	14.5	16	22.6	25
d	11/12/14/15/20	11/12/14/15/20	11/12/14/15/20	11/12/14/15/20	20/25/30/31	20/25/30/31	25/30/35/38	25/30/35/38	35/40/45/50	35/40/45/50

Dimensions

Model : SB07 (Base Plate Excluded)

Unit: mm

Series	08	09	10	11	14	15	16	17	20	21
b	122	122	143	143	180	180	207	207	255	255
d1	25	25	25	25	35	35	40	40	50	50
d2	90	90	96.5	96.5	124	124	150	150	185	185
d3	104	104	112	112	145	145	170	170	210	210
d4	114	114	130	130	165	165	190	190	240	240
d6	12	12	15	15	17	17	17	17	17	17
H1	56	72	65	81	85	104	96	113	120	138
H3	15/18	15/18	20	20	30	30	30	30	30	30
H5	33	46	31	47	38	57	42	61	98	117
H6	114	114	142	142	201	201	250	250	330	330
H7	64	64	76	76	97	97	111	111	136	136
Weight (Kg)	2.4	2.9	3.2	3.9	7.3	8.6	12.3	13.8	18.5	20.9
d	11/12/14/15/20	11/12/14/15/20	11/12/14/15/20	11/12/14/15/20	11/12/14/15/20	20/25/30/31	25/30/35/38	25/30/35/38	35/40/45/50	35/40/45/50

SB08 Spring-Applied Brake



Product Overview

SB08 Brake is a practical spring-applied safety brake. Its main purpose is to make the machine stop instantly. However, the selection & application of the SB08 brake needs to fit with the operation of the designed machine requirement, so as to guarantee normal operation of the brake.

Its major features are:

- Solid Structure
- Operation with Silent
- Simplified Installation & Maintenance easily
- The brake coil is covered and encircled by epoxy resin, while mechanical parts are also protected by heat-resistant coating materials so that can enhance the protection capacity of its inner structure.
- Heat Radiation Smoothly: The impurity generated from frictions during operation is blown away the fan easily.
- The brake can be installed onto the motor end-cap directly. (i.e. The motor end-cap is served as the brake surface which shall be composed of steel or cast iron coupled with precisely machining and smoothly in its surface.)

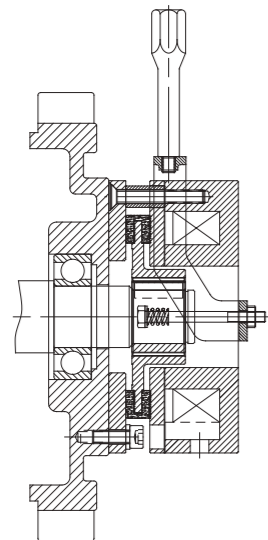

Brake Working Principle

The brake pad is installed onto the motor shaft through the splined gear, coupled with the flange fastened onto the motor end cap. Also, the brake pad is suppressed by the armature plate through the force of compressed brake springs so that the brake pad is hold between the armature plate and base plate by means of friction.

After installation, an air gap between the brake coil set and the armature plate is kept in specified value. When the power is connected to the brake coil, the force of the magnetic field is used for torque transmission. Then the armature plate is pulled in axial direction towards the brake coil set so that the brake pad is released and can be free rotation with the motor shaft.

Structure

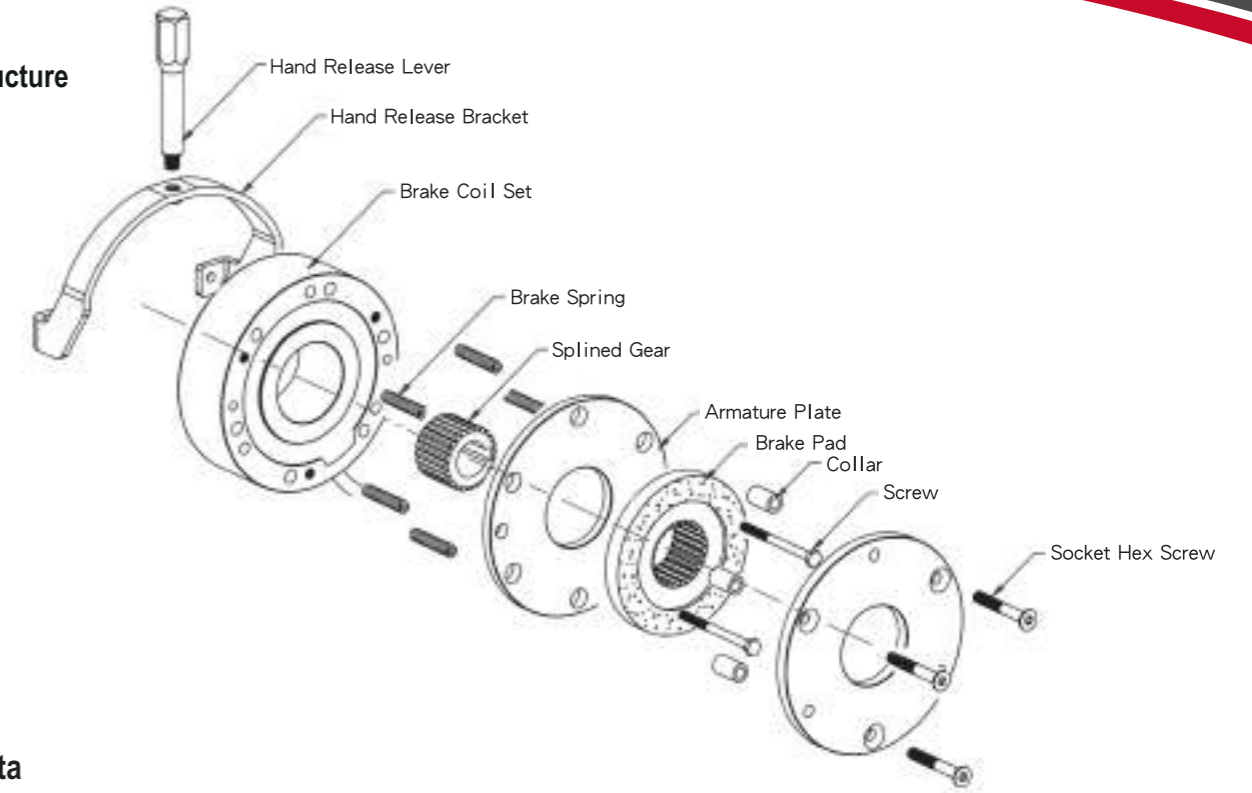

Technical Data

Model : SB08

Series	A5	A6	05	06	08	10	12	14	16
Rated Torque (N.M)	0.5	1	2	4	8	16	32	60	80
Max. Torque (Max-N.M)	1	2	4	6	12	23	46	95	125
Rated Voltage(DC-V)	DC96	DC96	DC96	DC96	DC96	DC96	DC96	DC96	DC96
Consumption Power (W)	7.6	8.3	14	20	25	31	40	50	55
Insulation Class	F	F	F	F	F	F	F	F	F
Max. Rotation Speed (RPM)	5000	5000	3000	3000	3000	3000	3000	3000	3000
Moment of Inertia of Rotation Parts (J·kg.m ²)	3.8×10 ⁻⁶	12×10 ⁻⁶	21×10 ⁻⁶	1.5×10 ⁻⁵	6.1×10 ⁻⁵	2×10 ⁻⁴	4.5×10 ⁻⁴	6.3×10 ⁻⁴	1.5×10 ⁻³
Suction Time of Amarture Plate (S)	0.025	0.030	0.030	0.045	0.057	0.076	0.115	0.210	0.220
Release Time of Amarture Plate (S)	0.035	0.045	0.045	0.025	0.029	0.035	0.045	0.050	0.071

Product Series Selection As Ordering

Model	Size Spec	Options	Brake Power	Brake Power
SB08	14	B Hand Release	0.06	C DC96V
SB08	A5	A Standard	Customization is available, Please contact with Sunso Industry Ltd.	A DC12V
	A6	B Hand Release		B DC24V
	05	C Hand Release & Dust-proof		C DC48V
	06	D Standard w/o Base Plate		D DC96V
	08	E Hand Release w/o Base Plate		E DC130V
	10	F Hand Release & Dust-proof w/o Base Plate		F DC190V
	12			G DC220V

SB08 Spring-Applied Brake

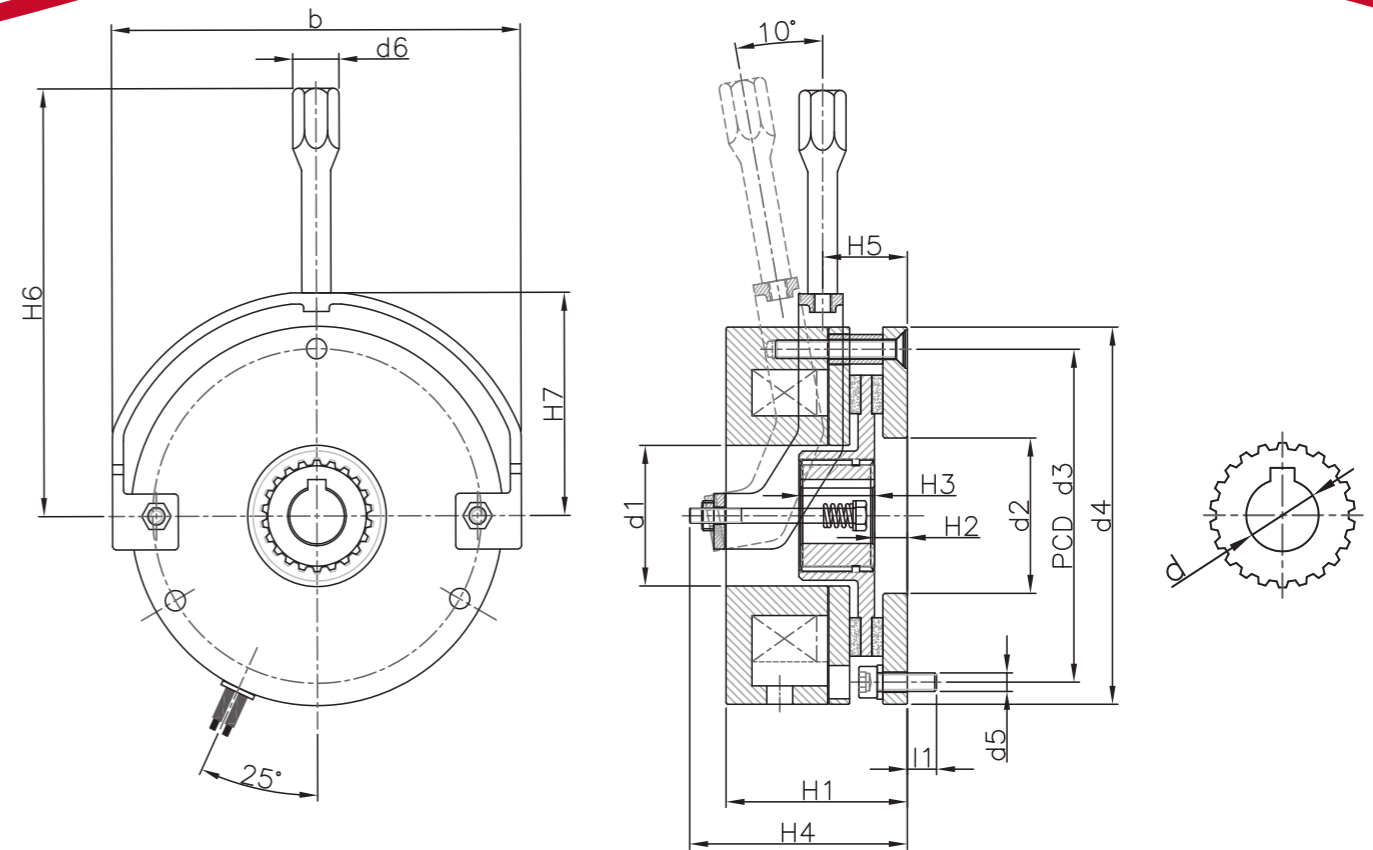
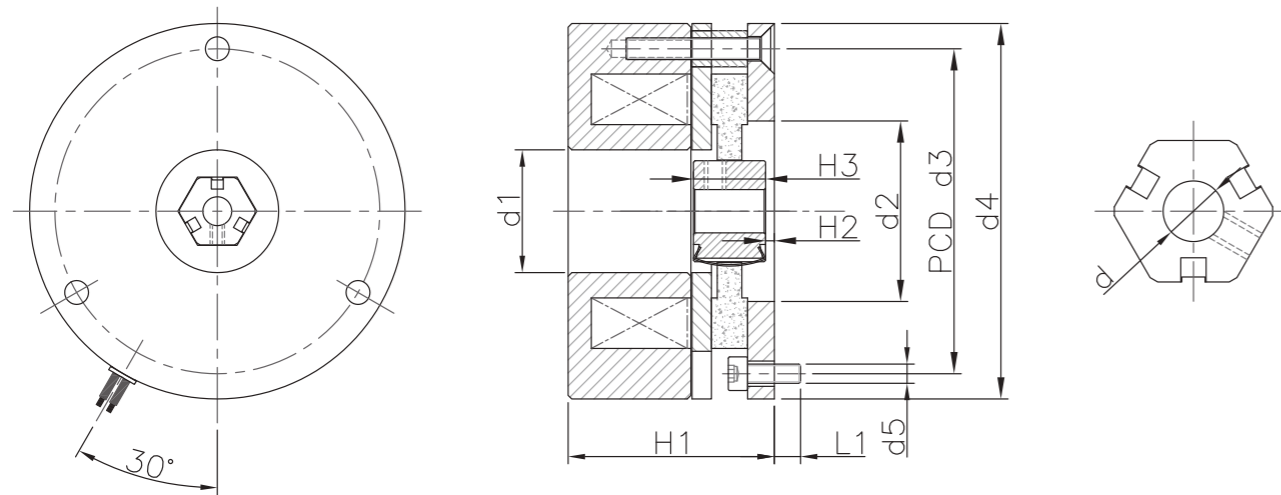

Customization can be available for the special specifications.

Customization can be available for the special specifications.

Dimensions

Model : SB08

Unit: mm

Series	A5	A6
d1	17	21
d2	25	30
d3	45	54
d4	52	62
d5	3xM3	3xM4
H1	4	4
H2	28.5	28.5
H3	1.2	0.45
H3	10	11.5
Weight (Kg)	0.5	0.7

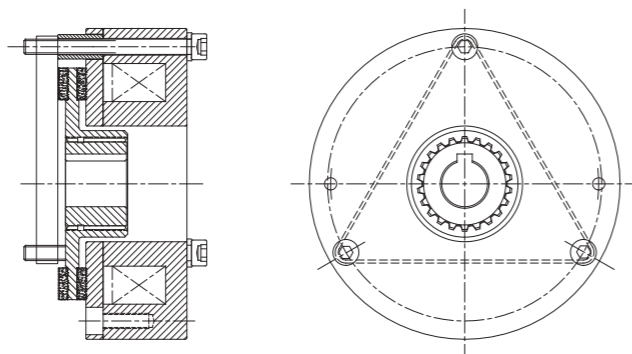

Dimensions

Model : SB08

Unit: mm

Series	05	06	08	10	12	14	16
b	NA	94	112	143	165	180	207
d1	28	31	38	44	52	60	70
d2	31	31	42	44	52	60	70
d3	66	72	90	112	132	145	170
d4	75	84	102	130	150	165	190
d5	3xM4	3xM4	3xM5	3xM6	3xM6	3xM8	3xM8
H1	6	8	8	16	14	14	16
d6	NA	12.7	12.7	15	15	17	17
H1	35.9	43	49	58	69	75	86
H2	NA	7	9	10	11	12	13
H3	15/18	18	20	20	25	30	30
H4	NA	52	59	72	85	90	102
H5	NA	21	23	35	39	43	48
H6	NA	107	115	142	162	201	250
H7	NA	52	60	76	89	97	111
d	8/10/11/12	10/11/12/14/15	11/12/14/15/20	11/12/14/15/20	15/17/20/25/27	20/25/30/31	25/30/35/38
Weight (Kg)	0.8	1.1	1.9	3.8	5.7	8.6	12



Product Overview

SB09 Brake is a normal-open type & slim-design safety brake, in particular with its superior responsive features, and plays strong effect for urgent stoppage of the loads. With its versified structure, 3-type brakes are available for simply assembly into various kinds of machines or motors.

Its major features are:

- Solid Structure
- Operation with Silent
- Simplified Installation & Maintenance easily
- The brake coil is covered and encircled by epoxy resin, while mechanical parts are also protected by heat-resistant coating materials so that can enhance the protection capacity of its inner structure.

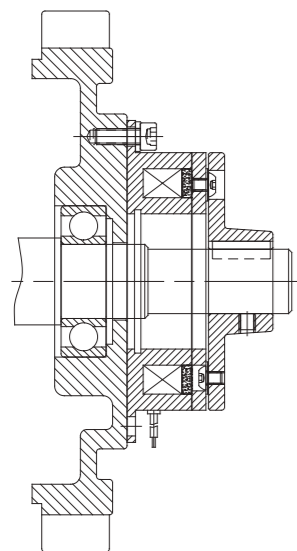

Brake Working Principle

The brake is composed of build-in brake coil set with friction materials, armature plate and flange. The brake coil set is installed onto the static component of machines or the end-cap of motor. The armature plate set is consisted of armature plate, flat spring and flange which is in the opposite side of the brake coil set with specified air gap. Then, assembly and fixed onto the rotation shaft correctly.

When power is connected to the brake coil, due to excitation effect, the armature plate with the flange is pulled by the force of electromagnetic field in axial direction toward the brake coil set so that the armature plate is stopped with the friction. As power off and excitation disappeared, the armature plate is separated from the brake coil set by means of the flat spring. Then, the motor shaft is released and rotation without braking.

Customized Production

A flange with fan type mounting onto the armature plate is designed for motor that can reduce installation space and also integrate with heat radiation & braking function.

Structure

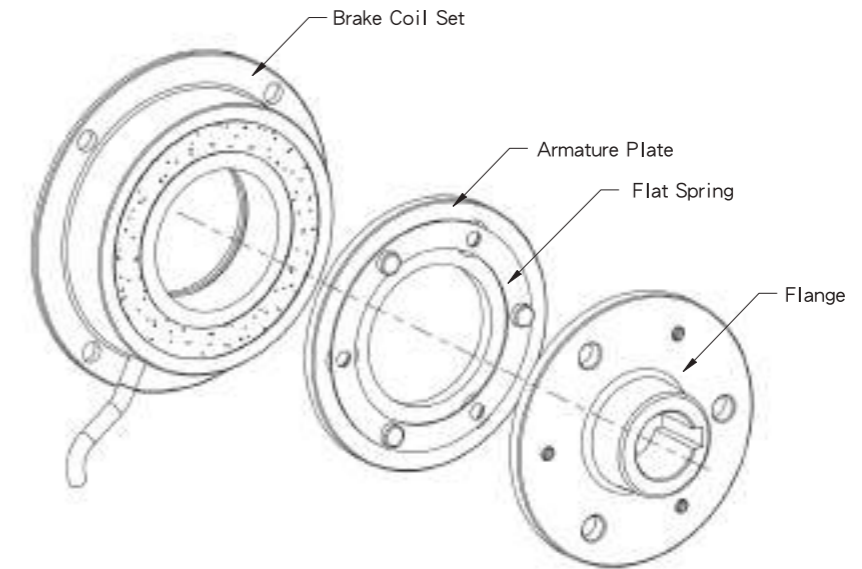

Technical Data

Model : SB09

Series	05	06	07	08	09	10	
Rated Torque (N.M)	6	15	25	50	100	200	
Rated Voltage(DC-V)	DC24	DC24	DC24	DC24	DC24	DC24	
Consumption Power (W)	11	15	20	25	35	45	
Insulation Class	B	B	B	B	B	B	
Max. Rotation Speed (RPM)	6000	6000	5000	4000	3000	2000	
Moment of Inertia of Rotation Parts (J·kg.m ²)	Flange type ^{Note1}	Ⓐ 4.23×10 ⁻⁵	Ⓐ 1.18×10 ⁻⁴	Ⓐ 4.78×10 ⁻⁴	Ⓐ 1.31×10 ⁻³	Ⓐ 4.80×10 ⁻³	Ⓐ 1.37×10 ⁻²
		Ⓑ 6.03×10 ⁻⁵	Ⓑ 1.71×10 ⁻⁵	Ⓑ 6.63×10 ⁻⁴	Ⓑ 1.81×10 ⁻³	Ⓑ 4.80×10 ⁻³	Ⓑ 1.90×10 ⁻²
		Ⓒ 6.03×10 ⁻⁵	Ⓒ 1.71×10 ⁻⁴	Ⓒ 6.63×10 ⁻⁴	Ⓒ 1.81×10 ⁻³	Ⓒ 4.80×10 ⁻³	Ⓒ 1.90×10 ⁻²
Suction Time of Amarture Plate (S)	0.015	0.016	0.018	0.027	0.035	0.065	
Release Time of Amarture Plate (S)	0.015	0.025	0.030	0.050	0.055	0.070	

Note1 : Ⓐ Without flange Ⓑ Inner flange Ⓒ Outer flange

Product Series Selection As Ordering

Model	Size Spec	Types	Brake Power	Voltage
SB09	08	C Outer flange	0.06	A DC12V
SB09	05	A Without flange	Customerized torque (1~999N.M) is available, Please contact with Sunso Industry Ltd. 0.06 means the torque required is 6N.M.	A DC12V B DC24V
	06	B Inner flange		
	07	B Inner flange		
	08	C Outer flange		
	09	C Outer flange		
	10	D Blade flange		

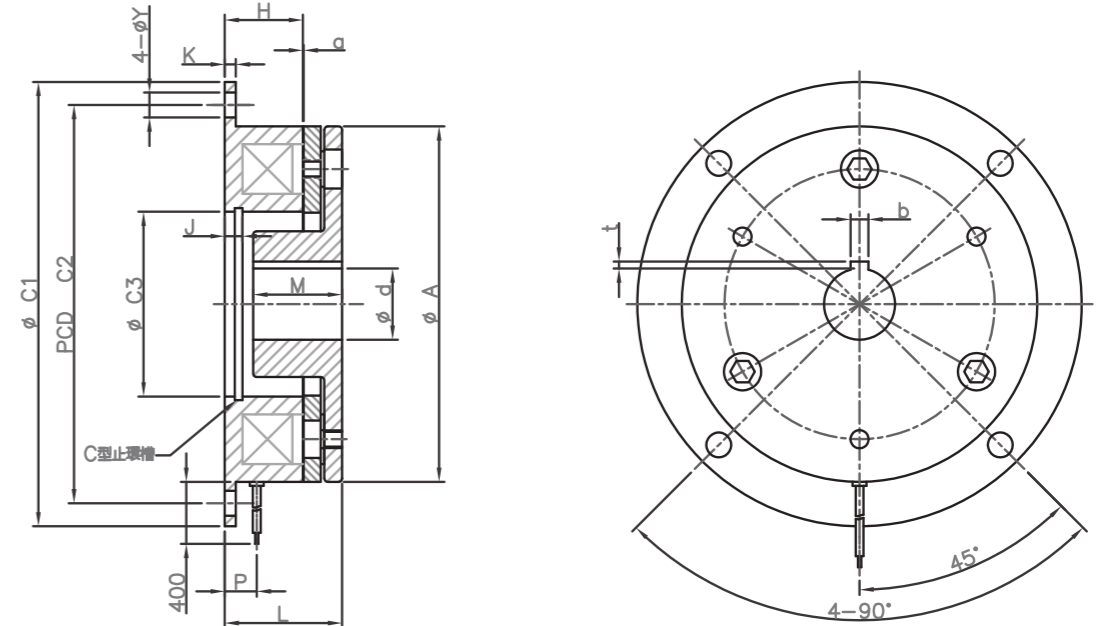
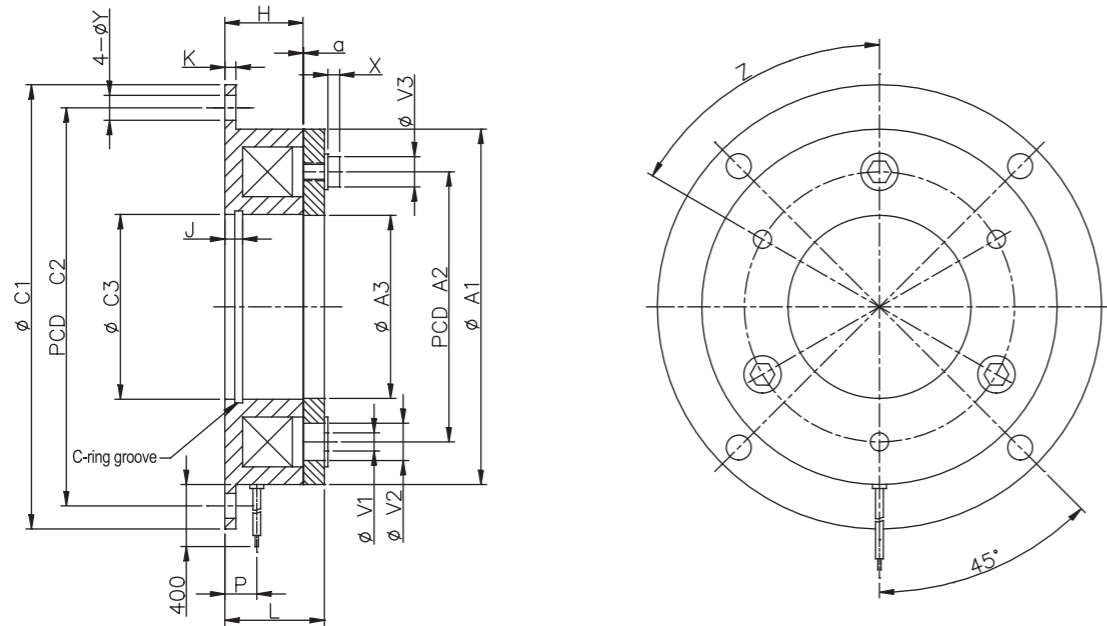

Dimensions **A** Without flange

Unit: mm

Series	05	06	07	08	09	10
A1	63	80	100	125	160	200
A2	46	60	76	95	120	158
A3	34.5	41.5	51.5	61.5	79.5	99.5
C1	80	100	125	150	190	230
C2	72	90	112	137	175	215
C3	35	42	52	62	80	100
V1	3-3.1	3-4.1	3-5.1	3-6.1	3-8.1	3-8.2
V2	3-6.3	3-8	3-10.5	3-12	3-15	3-18
V3	3-5.5	3-7	3-8.5	3-11	3-13	3-17
Y	5	6	7	7	9.5	9.5
Z	6-60°	6-60°	6-60°	6-60°	6-60°	6-60°
H	18	20	22	24	26	30
J	3.5	4.3	5	5.5	6	7
K	2.1	2.6	3.1	3.6	4.1	5.1
L	22	24.5	28	31	35	41.5
P	7.3	8.3	9	9.3	11.7	13.4
X	2.5	2.85	3.3	3.3	3.5	4.9
a	0.2	0.2	0.2	0.3	0.3	0.5
Weight (Kg)	0.28	0.5	0.91	1.68	3.15	5.9

Dimensions **B** Inner flange

Unit: mm

Series	05	06	07	08	09	10
A	63	80	100	125	160	200
C1	80	100	125	150	190	230
C2	72	90	112	137	175	215
C3	35	42	52	62	80	100
Y	5	6	7	7	9.5	9.5
H	18	20	22	24	26	30
J	3.5	4.3	5	5.5	6	7
K	2.1	2.6	3.1	3.6	4.1	5.1
L	25.5	28.5	33	37	42	50.5
M	15	20	25	30	38	45
P	7.3	8.3	9	9.3	11.7	13.4
a	0.2	0.2	0.2	0.3	0.3	0.5
d	12	15	20	25/30	30/40	40/50
b	4	5	5	7/7	7/10	10/12
t	1.5	2	2	3/3	3/3.5	3.5/3.5
Weight (Kg)	0.32	0.58	1.07	1.97	3.45	7.10

SB09 Power-ON Brake

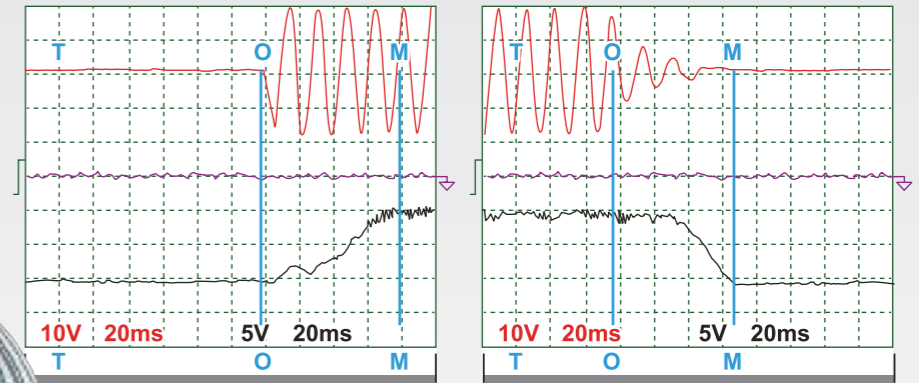
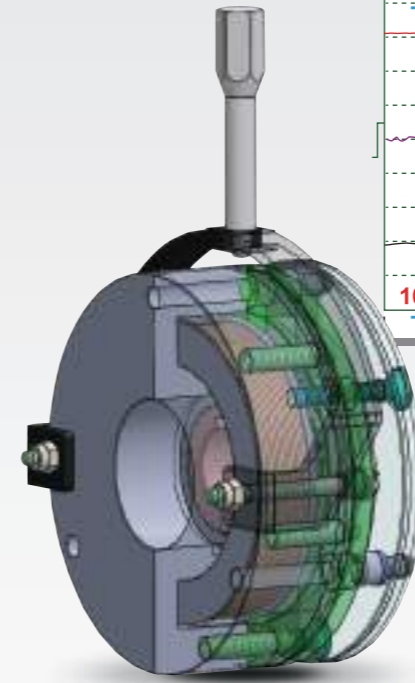
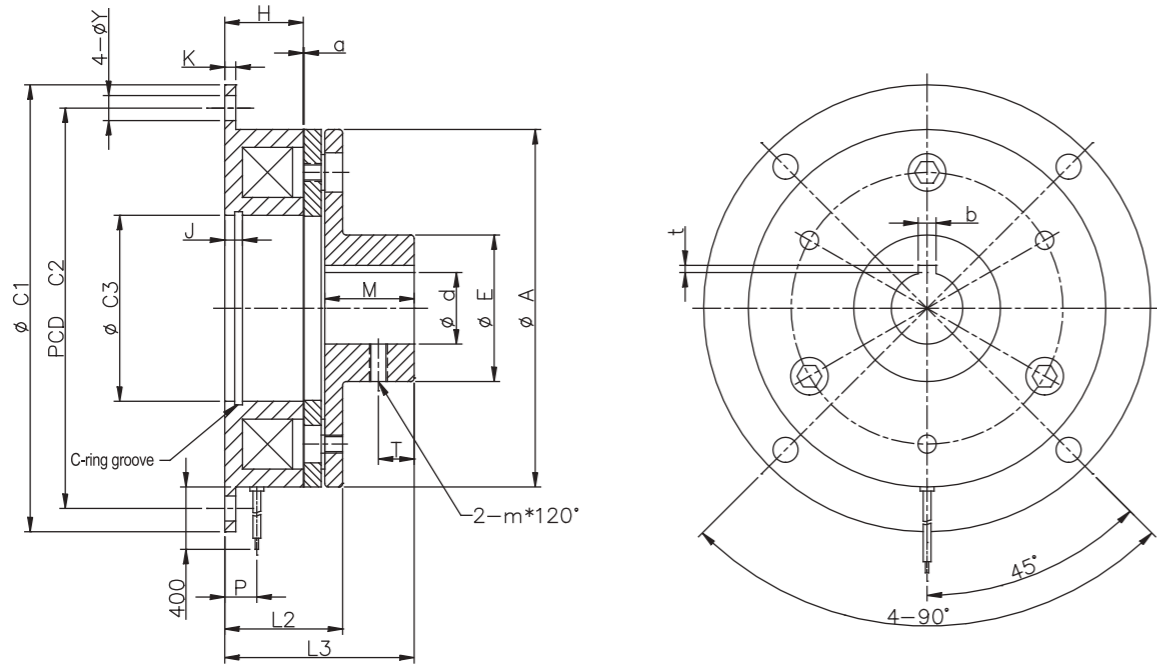

Dimensions Outer flange

Unit: mm

Series	05	06	07	08	09	10
A	63	80	100	125	160	200
C1	80	100	125	150	190	230
C2	72	90	112	137	175	215
C3	35	42	52	62	80	100
E	26	31	41	49	65	83
Y	5	6	7	7	9.5	9.5
H	18	20	22	24	26	30
J	3.5	4.3	5	5.5	6	7
K	2.1	2.6	3.1	3.6	4.1	5.1
L1	37	44.5	53	61	73	86.5
L2	25.5	28.5	33	37	42	50.5
M	15	20	25	30	38	45
P	7.3	8.3	9	9.3	11.7	13.4
T	6	8	10	12	15	18
a	0.2	0.2	0.2	0.3	0.3	0.5
m	M4	M5	M5	M6	M8	M8
d	12	15	20	25/30	30/40	40/50
b	4	5	5	7/7	7/10	10/12
t	1.5	2	2	3/3	3/3.5	3.5/3.5
Weight (Kg)	0.32	0.58	1.07	1.97	3.45	7.10

